



Bobcat®

Operation & Maintenance Manual



9996010(AU) KAW FX801V 25.5HP 52"SD

S/N 99960100070 & Above

9996011 KAW FX801V 25.5HP 61"SD

S/N 99960110070 & Above

9996012(AU) KAW FX850V 27HP 61"SD

S/N 99960120070 & Above

9996013 FX850 EFI 29.5HP 61"SD

S/N 99960130070 & Above

www.Bobcat.com

Printed in U.S.A.



ADVERTENCIA

El estado de California hace saber que los gases de escape de este producto contienen productos químicos que producen cáncer, defectos de nacimiento y otros daños en el proceso de reproducción humana.

WARNING

The engine exhaust from this product contains chemicals known to the State of California to cause cancer, birth defects or other reproductive harm.

CALIFORNIA PROPOSITION 65



WARNING: Cancer and Reproductive Harm - [www. P65Warnings.com](http://www.P65Warnings.com)



ADVERTENCIA: Cáncer y Daño Reproductivo - www.P65Warnings.ca.gov

IMPORTANT!

It is a violation of California Public Resource Code Section 4442 or 4443 to use or operate the engine on any forest-covered, brush-covered or grass-covered land unless the engine is equipped with a spark arrestor, as defined in Section 4442, maintained in effective working order or the engine is constructed, equipped, and maintained for the prevention of fire.

To acquire a spark arrestor for your unit, see your Dealer.

Please refer to the engine manufacturer's information included with the machine.

Labeled power ratings are supplied by the engine manufacturer in accordance with SAE testing and gross/net power rating standards (J1940, J1995, J1349).

IMPORTANT MESSAGE

Thank you for purchasing this Bobcat® product. You have purchased a world class mowing product, one of the best designed and built anywhere.

This machine comes with an Operation and Maintenance Manual. The useful life and good service you receive from this machine depends to a large extent on how well you read and understand these manuals. Treat your machine properly, lubricate and adjust it as instructed, and it will give you many years of reliable service.

Your safe use of this product is one of our prime design objectives. Many safety features are built in, but we also rely on your good sense and care to achieve accident-free operation. For best protection, study the manuals thoroughly. Learn the proper operation of all controls. Observe all safety precautions. Follow all instructions and warnings completely. Do not remove or defeat any safety features. Make sure those who operate this machine are as well informed and careful in its use as you are.

See a Bobcat dealer for any service or parts needed. Our service team ensures that you continue to receive the best results possible from our products. You can trust our replacement parts because they are manufactured with the same high precision and quality as the original parts.

We design and build equipment to serve many years in a safe and productive manner. For longest life, use this machine only as directed in the manuals, keep it in good repair and follow safety warnings and instructions. You'll always be glad you did.

Bobcat Company
One Bobcat Lane
Johnson Creek, WI 53038
www.Bobcat.com

TABLE OF CONTENTS	PAGE
REGULAR MAINTENANCE ITEMS & ACCESSORIES	2
GENERAL SAFETY INFORMATION	3
SAFETY	4-11
LABELS	12-14
CONTROLS	15-17
PUSHING THE MACHINE	18
PRE-OPERATION CHECKLIST	19
OPERATION	20-23
MAINTENANCE CHART	24
MAINTENANCE RECORD	25
MAINTENANCE / STORAGE	26-33
ADJUSTMENTS	34-41
BELT REPLACEMENT	42-43
SPECIFICATIONS	44, 45

Mower Serial Number _____

Engine Serial Number _____

NOTES:





YOUR BOBCAT DEALER:

ADDRESS:

PHONE:

06/2020

REGULAR MAINTENANCE ITEMS

 <p>BATTERY 4171099 An AGM battery charger is required (4171973)</p>	 <p>TRANSAXLE FILTER 4176891</p>
 <p>DECK BELT 9996010 4176908 9996011 4176344 9996012 4176344 9996013 4176344</p>	 <p>DECK BLADE 9996010 112111-02 9996011 112111-03 9996012 112111-03 9996013 112111-03</p>
 <p>DRIVE BELT 4174132</p>	
<p>ENGINE OIL 7354875 SAE 10W30 CK-4/SN (1 qt)</p>	<p>TRANSAXLE OIL 7354882 - 2 gallon SAE 15w40 CE/SG (3.5 qt per transaxle)</p>

NOTE: Contact your Bobcat dealer for engine and parts replacements.

NOTE: Always verify Part Numbers with your Bobcat dealer.

ACCESSORIES

- Mulching Kit
- ECO Plate Kit
- Light Kit
- Striping Kit
- Hitch Kit
- No-Flat Caster Wheels
- Boss Vac Collection System

GENERAL SAFETY INFORMATION

⚠ WARNING

To avoid serious injury:

- Before you begin the maintenance procedure, ensure that engine is turned OFF and has cooled down, key is removed from the ignition, and that the **NEGATIVE Battery terminal** is disconnected.
- Use proper personal protective equipment during all phases of operation and maintenance.
- **ALWAYS** shut off engine before leaving the operator's seat to perform any portion of the procedures listed in this manual.

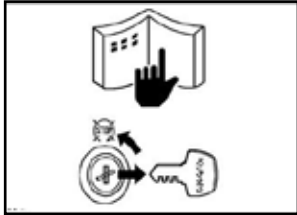

BEFORE YOU START SERVICE

- Read all instructions and safety instruction in the manual and on your machine safety decals.
- Clean the work area and machine.
- Park the machine on a stable and level ground, and set the parking brake.
- Stop the engine, then remove the key
- Disconnect the battery negative cable.
- Hang a "DO NOT OPERATE" tag in the operator station.

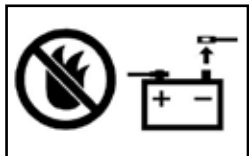

FIRE PREVENTION

- Fuel is very flammable and explosive under some conditions. Do not smoke or let flames or sparks in your work area.
- To prevent sparks from an accidental short circuit, always disconnect the negative battery cable first and connect it last.
- Battery gas can cause an explosion. Keep the sparks and open flame away from the top of battery, especially when you charge the battery.



BEFORE YOU START SERVICE

- Wear clothes appropriate for working on equipment.
- Do not wear loose-fitting clothes as they may catch on the machine.
- When working on the equipment, use all safety gear, such as a helmet, safety glasses and shoes, that are required by law or regulation.
- Never perform maintenance while drowsy or under the influence of alcohol or drugs.

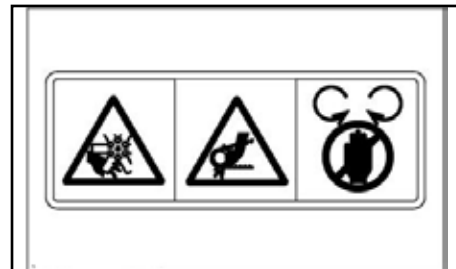

- The engine, muffler, hydraulic line, etc, have parts that remain very hot even after the engine has been stopped. Be sure to avoid these parts as touching them can result in burns. Hydraulic fluid and oil also remain hot. **DO NOT** attempt to remove caps and plugs, etc, before these fluids had cooled.

SAFETY

NOTICE !!!

Unauthorized modifications may present **extreme** safety hazards to operators and bystanders and could also result in product damage.

We strongly warn against, reject and disclaim any modifications, add-on accessories or product alterations that are not designed, developed, tested and approved by the Engineering Department. Any product that is altered, modified or changed in any manner not specifically authorized after original manufacture-including the addition of "after-market" accessories or component parts not specifically approved -will result in the Warranty being voided.

Any and all liability for personal injury and/or property damage caused by any unauthorized modifications, add-on accessories or products not approved will be considered the responsibility of the individual(s) or company designing and/or making such changes. We will vigorously pursue full indemnification and costs from any party responsible for such unauthorized post-manufacture modifications and/or accessories should personal injury and/or property damage result.



This Operator's Manual should be regarded as part of the machine. Suppliers of both new and second-hand machines must make sure that this manual is provided with the machine.



¡LEA EL INSTRUCTIVO!

Si no lee Ingles, pida ayuda a alguien que si lo lea para que le traduzca las medidas de seguridad.

EXAMPLE:



Model
9997010

Serial Number
999701000050

Bobcat Company
West Fargo, ND 58078 USA



This symbol means:
ATTENTION!
BECOME ALERT!

Your safety and the safety of others is involved.

Signal word definitions:

The signal words below are used to identify levels of hazard seriousness. These words appear in this manual and on the safety labels attached to the machines. For your safety and the safety of others, read and follow the information given with these signal words and/or the symbol shown above.

DANGER

DANGER indicates an imminently hazardous situation which, if not avoided, **WILL** result in death or serious injury.

WARNING

WARNING indicates a potentially hazardous situation which, if not avoided, **COULD** result in death or serious injury.

CAUTION

CAUTION indicates a potentially hazardous situation which, if not avoided, **MAY** result in minor or moderate injury. It may also be used to alert against unsafe practices or property damage.

CAUTION

CAUTION used without the safety alert symbol indicates a potentially hazardous situation which, if not avoided, **MAY** result in property damage

MODEL NUMBER: This number appears on sales literature, technical manuals and price lists.

SERIAL NUMBER: This number appears only on your unit. It contains the model number followed consecutively by the serial number. Use this number when ordering parts or seeking warranty information. Located under seat plate on frame of unit.

PREPARING FOR SAFE OPERATION

Operator preparation and training

- **Read, understand, and follow instructions and warnings in the manual and on the machine, engine, and attachments. If you don't understand something or it is unclear; contact your Bobcat dealer representative for clarification.**
- Become familiar with the safe operation of the equipment, operator controls and safety signs. Be prepared to stop the engine and attachments quickly in an emergency. Do not operate or allow another person to operate this machine if there are any questions about safety.
- Only allow operators who are responsible, trained, familiar with the instructions, and physically capable to operate or service the machine. The owner is responsible for training the users.
- Wear appropriate clothing, including long trousers and safety goggles or safety glasses with side shields when operating mower. Do not operate barefoot or wearing open sandals. Long hair, loose clothing or jewelry may get tangled in moving parts.
- If an operator or mechanic cannot read English, it is the owner's responsibility to explain this material to them.



CAUTION

This machine produces sound levels in excess of 85dBA at the operator's ear. Extended periods of exposure can cause hearing loss.

- Wear hearing protection.
- Never allow children, unskilled or improperly trained people to operate this equipment. Local regulations can restrict the age of the operator.
- Only adults and mature teenagers should operate a mower. Mature teenagers should have adult supervision. Be sure a teenager:
 1. Has read and understands the operator manual and understands the risks involved.
 2. Is sufficiently mature to use caution.
 3. Is of sufficient size and weight to operate the controls comfortably and to manage the mower without taking risks.

- Data indicates that those operators age 60 years and above are involved in a large percentage of riding mower-related injuries. Those operators should evaluate their ability to operate the riding mower safely enough to protect themselves and others from injury.
- Do not carry passengers, especially small children. They may fall off and be seriously injured.
- Keep warning labels and this operator's manual legible and intact. Replacement labels and manuals are available from the factory.
- Do not operate machine while under the influence of drugs or alcohol or any other condition of impairment.
- The owner/user can prevent and is responsible for accidents or injuries occurring to themselves, other people or property.



Site preparation and circumstances

- Evaluate the terrain to determine what accessories and attachments are needed to properly and safely perform the job. Only use accessories and attachments approved by the manufacturer.
- Clear the area to be mowed of objects such as rocks, toys, wire or other debris that may be picked up or thrown by the mower.
- Be sure the area is clear of pets and people, especially young children. Never assume they will remain where you last saw them. Stop the machine if any enter the area.
- Mow only in daylight or in good artificial light.
- Do not mow wet grass as tires may lose traction.

SAFETY

MACHINE PREPARATION

- Do not tamper with or defeat safety devices. Keep guards, shields and interlock safety devices in place and in proper working condition. They are for your protection.
- Keep all fasteners such as nuts, bolts and pins well secured.
- Visually inspect blades, blade bolts and the cutterdeck assembly for wear or damage. Replace worn or damaged blades and bolts to preserve balance.
- Verify that machine and attachments, if any, are in good operating condition.
- Grass catcher components are subject to wear, damage and deterioration which could expose moving parts or allow objects to be thrown.

FUELING

WARNING



- Gasoline can be extremely flammable; gasoline vapors are explosive. Use extra care when handling. A fire or explosion from gasoline can burn you or others and /or cause property damage.
- Fill the fuel tank outdoors on level ground, in an open area, when the engine is cold and wipe up any spilled gasoline.
- If the engine has been running, stop the engine and allow to cool for several minutes.
- Do not smoke, stay away from open flames or other possible ignition sources.
- Refuel outdoors, do not refuel in indoors or in an enclosed trailer.
- Use a funnel.
- Do not overfill. Fill to the bottom of the filler neck. The empty space allows for expansion. Overfilling may result in fuel leakage or damage to the engine or emissions system.
- If fuel is spilled, do not attempt to start the engine until the spill is cleaned up and vapors have cleared.
- Replace caps on fuel containers and tanks securely.
- Do not operate without the entire exhaust system in place and in good working condition.

WARNING



Under certain conditions, static electricity can cause sparks during fueling and start fires or cause explosions. Flowing fuel can generate static electricity. To prevent static electricity sparks:

- Keep fuel containers electrically grounded.
- Do not fill containers in a vehicle or on a truck or trailer bed with a plastic liner. Fill containers on the ground away from the vehicle.
- When practical, remove gas powered equipment from the truck or trailer and refuel it on the ground. If equipment must be refueled on the truck or trailer, refuel from a portable container rather than a dispenser nozzle.
- If a dispenser nozzle must be used, keep the dispenser nozzle in contact with the rim of the fuel tank or container opening until fueling is complete. Do not use a nozzle lock-open device
- Replace caps on fuel cans and tanks securely.
- Fill the fuel tank outdoors.
- Store fuel only in containers specifically designed for fuel.

WARNING



Gasoline is harmful or fatal if swallowed. Long-term exposure to vapors has caused cancer in laboratory animals.

- Avoid prolonged breathing of vapors.
- Keep face away from nozzle and gas tank/container opening.
- Keep away from eyes and skin.
- Do not siphon by mouth.

OPERATING SAFELY WARNING

Operating engine parts, especially the muffler, become extremely hot. Severe burns can result from contact. Debris such as grass clippings, leaves, brush, etc. can catch fire.

- Allow engine parts, especially the muffler, to cool before touching.
- Remove accumulated debris from engine and muffler area.

WARNING

Engine exhaust contains carbon monoxide, which is an odorless gas that can kill you.

DO NOT run the engine indoors or in a confined small area (such as an enclosed trailer) where carbon monoxide fumes can collect.

Starting

- Start only according to instructions in this manual or on the machine.
- Lightning can cause severe injury or death. If lightning is seen or thunder is heard in the area, DO NOT operate the machine; seek shelter.
- Be sure all drives are in neutral and parking brake is engaged before starting engine. Use seat belts with the roll bar in the raised and locked position.
- Do not change engine governor settings or overspeed the engine. Operating the engine at excessive speed can increase the hazard of personal injury.

Operation

- Do not put hands or feet near rotating parts or under the machine. Keep clear of the discharge opening at all times.
- This mower was designed for use by one operator. Keep all others away during operation.
- Do not operate when people, especially children, or pets are in the area.
- Stop the machine if anyone enters the area.
- Do not mow in reverse unless absolutely necessary. Always look down and behind before and while backing.
- Slow down and use caution when making turns and crossing roads and sidewalks.
- Stop blades when not moving.
- Stop blades when crossing surfaces other than grass.
- Do not mow with the discharge deflector raised, removed or altered unless there is a grass collection system or mulch kit in place and working properly.
- Do not start the cutting blades until you are ready to start mowing.

- Use care when approaching blind corners, shrubs, trees, or other objects that may obscure vision.
- Do not direct discharge towards others.
- Avoid discharging material against a wall or obstruction. Material may ricochet back toward the operator.
- Obey safety instructions. Failure to do so may cause injury to yourself and/or others.
- Never leave a running machine unattended. Park on level ground, turn off blades, stop engine and remove key before leaving the operator position.

Stopping

- Park the machine on level ground. Stop the engine, remove the key and wait for all parts to stop moving before:
 - Checking cleaning or working on the mower.
 - After striking a foreign object or an abnormal vibration occurs. Inspect and make any necessary repairs before restarting and operating the mower.
 - Before clearing blockages or unclogging.
- Park the machine on level ground. Stop the engine, remove the key and wait for all parts to stop moving.
 - Whenever you leave the mower.
 - Before refueling.
 - Before emptying the grass catcher.
- Be sure all drives are in neutral and parking brake is engaged before starting engine. Use seat belts with the roll bar in the raised and locked position.
- Do not change engine governor settings or overspeed the engine. Operating the engine at excessive speed can increase the hazard of personal injury.

CHILDREN

- Tragic accidents can occur if the operator is not alert to the presence of children. Children are often attracted to the machine and the mowing activity. Never assume that children will remain where you last saw them.
- Keep children out of the operating area and under the watchful care of a responsible adult other than the operator.
- Do not carry children, even with the blade(s) shut off. Children could fall off and be seriously injured or interfere with safe machine operation. Children who have been given rides in the past could suddenly appear in the mowing area for another ride and be run over or backed over by the machine.

SAFETY

MOWING SLOPES

⚠ WARNING

Operating on wet grass or steep slopes can cause sliding and loss of control. Wheels dropping over edges, ditches, steep banks, or into water can cause roll overs, which may result in serious injury, death or drowning. Slopes are a major factor related to accidents. Operation on slopes requires extra caution.

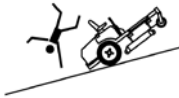

- DO NOT mow slopes when grass is wet.
- DO NOT mow near drop-offs or water.
- Reduce speed and use extreme caution on slopes.
- Do not operate machine under any condition where traction, steering, or stability is in question. Tires could slide even if the wheels are stopped.
- Avoid sudden turns or rapid speed changes.
- Keep ROPS in the raised and locked position and use seat belt.
- Do not mow on slopes if uneasy or uncertain. Ultimate responsibility for safe operation on slopes rests with the operator.
- Do not mow excessively steep slopes.
- With ride-on machines, including articulated steering machines, mow up and down slopes, not across, except for zero-turn machines. Zero-turn machines should mow across slopes.
- With walk-behind machines, mow across slopes, not up and down.
- With zero-turn machines, mow across slopes, not up and down. If the machine will not stay on the slope, it is too steep.
- Mid-mount zero-turn (belly mounted deck) machines have much greater traction pointed up slope than down slope. Be aware that traction may be lost going down a slope. Do not operate a mid-mount zero-turn on slopes it cannot back up.
- Avoid starting or stopping on a slope. If tires lose traction, disengage the blades and proceed slowly straight down the slope.
- With a zero-turn machine, if tires lose traction going down a slope, steering control may be regained by speeding up.
- Keep all movement on the slopes slow and gradual. Do not make sudden changes in speed or direction.
- Do not turn on slopes unless necessary, and then turn slowly and downhill when possible.
- Stay away from slopes if the ground is loose or if caught in the rain during mowing.

- Use extra care with grass catchers or other attachments. These can change the stability of the machine.
- Remove obstacles such as rocks, tree limbs, etc. from the grass cutting area.
- Avoid driving over obstacles such as ruts, holes, rocks and roots whenever possible. Be alert to dips and rises. Uneven terrain can overturn a mower or cause it to slide. Tall grasses can hide obstacles.
- Do not mow drop-offs, ditches or embankments. The machine could suddenly turn over if a wheel runs over the edge or an edge caves in.
- Follow the manufacturer's recommendations for wheel weights or counterweights to improve stability.
- Be aware that operating on wet grass, across steep slopes or downhill may cause the mower to lose traction. Loss of traction to the drive wheels may result in sliding and loss of braking and steering. Use a walk behind mower and /or hand trimmer near drop-offs, ditches, steep banks or water.

⚠ WARNING

A ROPS is a Roll-Over Protective Structure. The ROPS reduces the risk of serious or fatal injury in the unlikely event of a tip over, although the system cannot protect the operator from all possible injuries. It is not designed, made, or intended to provide protection for a machine that is driven off an embankment, retaining wall or similar situation. A ROPS does not replace the need to exercise care when operating on slopes.

IMPORTANT:

- The ROPS is an integral and effective safety device. DO NOT remove or alter the ROPS.
- Keep Roll Bar in the raised position and use the seat belt.
- There is NO roll over protection when the roll bar is lowered. Lower the roll bar only when necessary. DO NOT use the seat belt when the roll bar is in the lowered position. Raise the roll bar as soon as clearance permits.
- Do not cut, drill, modify or repair a ROPS in any manner.
- Replace a damaged ROPS.
- Use extreme care when working close to fences, ditches, trees, and on hills.
- Check overhead clearances carefully before driving under any objects.
- DO NOT leave the operator's position while unit is running.
- DO NOT carry passengers.

TRANSPORTING**⚠ WARNING**

Loading a machine onto a trailer or truck increases the possibility of tip-over and could cause serious injury or death.

- Use extreme caution when operating a machine on a ramp.
- Have the ROPS in the up position and use the seat belt when loading or unloading the machine unless the ROPS will not clear the top of an enclosed trailer.
- Use only a full-width ramp; do not use individual ramps for each side of machine.
- Avoid sudden acceleration or deceleration while driving the machine on a ramp as this could cause a loss of control or a tip-over situation.
- Shut off fuel when transporting.
- Secure the machine to the truck or trailer.

⚠ WARNING**TOWING EQUIPMENT SAFETY**

- Use extra caution when towing.
- Only tow equipment that has a hitch designed for towing.
- Do not attach towed equipment except at the hitch point.
- Follow manufacturer's recommendations for towed equipment, including weight limits and towing on slopes. The weight of the towed equipment may cause loss of traction or loss of control. The mower will respond differently when towing, particularly on slopes. Towed equipment may cause loss of traction and loss of control. For example, the load on a towed trailer may shift during operation adversely affecting control of the mower and towed equipment.
- Read all safety and operating instructions pertaining to the mower and equipment before towing and understand and familiarize yourself with the limitations of the mower and towed equipment prior to towing.
- Always put the ROPS (Roll-Over Protective Structure) in the raised position before towing and always use a seat belt. Wear the seat belt whenever the ROPS is raised.
- Always use extra caution when making tight turns. Make wide turns to avoid jack-knifing.

- Know the conditions such as wet grass/ground, slopes, loose gravel, etc., as these factors will affect the traction and handling characteristics of the mower and towed equipment. For example, wet grass reduces traction and control of the mower and towed equipment.
- Travel slowly when towing and allow for extra distance to stop.
- Never allow children or others in or on towed equipment.
- Always park on level ground when towed equipment is attached, and always apply the parking brake when leaving the mower.
- Maximum weight of towed equipment recommended for this mower is 700 lbs. when operating on flat ground. Note: Maximum weight may be reduced depending on specific conditions as noted above. The operator must judge the conditions and determine if towing is appropriate and what maximum weight would be safe to tow.
- Maximum tongue weight should not exceed 25 lbs.

SAFETY

MAINTENANCE SAFETY

In General

- Keep the machine in good working order.
- Maintain machine according to manufacturer's schedule and instructions for maximum safety and best mowing results.
- Park machine on level ground.
- Never allow untrained personnel to service machine.
- Adjust or repair only after the engine has been stopped and the blades have quit rotating.
- Inspect grass catcher components regularly. If worn, damaged or deteriorated, they may expose moving parts or allow objects to be thrown.
- Replace worn, damaged or faulty parts. For best results, always replace with parts recommended by the manufacturer.
- Disconnect battery or remove spark plug wire(s) before making any repairs. Disconnect the negative terminal first and the positive last. Reconnect positive first and negative last.
- Do not dismantle the machine without releasing or restraining forces which may cause parts to move suddenly.
- Provide adequate support for lifted machine or parts if working beneath.
- Keep hands or feet away from moving parts.
- Clean up oil or fuel spillage thoroughly.
- Replace faulty mufflers.
- To reduce fire hazards, keep the engine, muffler, battery compartment and fuel storage area free of grass, leaves, debris buildup or grease.
- Hydraulic fluid can penetrate skin, use paper to check for leaks. Relieve hydraulic pressure before disconnecting hoses. Make sure connections are tight and hoses are in good condition.

HYDRAULIC SYSTEM

WARNING



Hydraulic fluid escaping under pressure can penetrate skin and cause injury. Fluid accidentally injected into the skin must be surgically removed within a few hours by a doctor familiar with this form of injury or gangrene may result.

- If equipped, make sure all hydraulic fluid hoses and lines are in good condition and all hydraulic connections and fittings are tight before applying pressure to hydraulic system.
- Keep body and hands away from pinhole leaks or nozzles that eject high pressure hydraulic fluid.
- Use cardboard or paper, not your hands, to find hydraulic leaks.
- Safely relieve all pressure in the hydraulic system by placing the motion control levers in neutral and shutting off the engine before performing any work on hydraulic system.

WARNING

Charging or jump starting the battery may produce explosive gases. Battery gases can explode causing serious injury.

- Keep sparks, flames, or cigarettes away from battery.
- Ventilate when charging or using battery in an enclosed space.
- Make sure venting path of battery is always open once battery is filled with acid.
- Always shield eyes and face from battery!

WARNING

If the ignition is in the "ON" position there is potential for sparks and engagement of components. Sparks could cause an explosion or moving parts could accidentally engage causing personal injury. Be sure ignition switch is in the "OFF" position before charging the battery.

BLADES



WARNING

- Mower blades are sharp and can cut. Use extra caution when handling. Remove obstructions with care. Wrap the blade(s) or wear gloves.
- Be aware that rotating one blade on multi blade mowers can cause other blades to rotate.
- Only replace blades. Never straighten or weld them.
- Keep other persons away from blades.

BATTERY



WARNING

Battery electrolyte contains sulfuric acid which is poisonous and can cause severe burns. Swallowing electrolyte can be fatal. Batteries can produce hydrogen gas which is explosive.

- When working with battery electrolyte, use protective equipment such as, but not limited to, goggles, face shield, rubber gloves and apron.
- Avoid leaning over a battery.
- Do not expose a battery to open flames or sparks.
- Be sure batteries with filler caps are properly filled with fluid.
- Do not allow battery acid to contact eyes or skin. Flush any contacted area with water immediately and get medical help.
- Charge batteries in an open, well ventilated area, away from sparks and flames. Unplug charger before connecting or disconnecting from battery.

Jump starting

1. Be sure the jumper cables are in good condition. Turn off the ignition and all electrical accessories on both machines.
2. Position the machine with a good (charged) battery next to but not touching the machine with the dead battery so jumper cables will reach.
3. When making cable connections:
 - make sure the clamps do not touch anywhere except to intended metal parts.
 - Never connect a positive ("+" or red) terminal to a negative ("- " or black) terminal.
 - Make sure the cables won't get caught in any parts after the engines are started.
4. Connect one end of the first jumper cable to the **positive** terminal on one battery. Connect the other end to the **positive** terminal on the other battery.
5. Connect one end of the other cable to the **negative** terminal of the machine with a good (charged) battery. Make the final connection on the engine of the machine to be started, away from the battery.
6. Start the vehicle with the good battery, then the machine with the discharged battery.
7. Remove the cables in the exact reverse order of installation. When removing each clamp, take care it does not touch any other metal parts while the other end remains attached.

STORAGE SAFETY

- Stop the engine and allow to cool before storing.
- Drain the fuel tank outdoors only.
- Store fuel in an approved container in a cool, dry place.
- Keep the machine and fuel containers in a locked storage place to prevent tampering and to keep children from playing with them.
- When the machine is to be parked, stored or left unattended, lower the cutterdeck unless a positive mechanical lock is used.
- Do not store the machine or fuel container near heating appliances with an open flame such as a water heater or an appliance with a pilot light.
- Keep gasoline storage area free of grass, leaves and excessive grease to reduce fire hazard.
- Clean grass and debris from cutting units, drives, mufflers and engine to help prevent fires.

LABELS

WARNING

BEFORE STARTING OR SERVICING:



Read and understand the Operator's Manual & labels.

- Be sure machine is in safe operating condition.
- Move traction levers to neutral lock, parking brake to ON.
- Set PTO switch to OFF.

BEFORE LEAVING SEAT:

- Move traction levers to neutral lock, parking brake to ON.
- Set PTO switch to OFF.
- Turn engine keyswitch to OFF.
- Remove key.

WARNING

AVOID SERIOUS INJURY OR DEATH:

- Read and obey the Operation & Safety Manual.
- Remove objects that could be thrown by the blades.
- Use caution on slopes. Stay off slopes the machine cannot back up.
- Stop blades and drive down slowly if machine slides or stops going on a slope.
- Do not mow when children or others are around.
- Do not carry a child or passenger - even with blades off.
- Look down and behind before and while backing.
- Do not operate unless trained.
- Do not operate unless guards, shields, and interlocks are in place and working.
- Replace labels and Operation & Safety Manual if lost or damaged.

ADVERTENCIA

- Leer el manual del operador. No permitir que personas no capacitadas para ello usen la máquina.
- Mantener los protectores en su lugar y sus tornillos debidamente fijados.
- Antes de limpiar, ajustar o reparar este equipo, apagar todos los mandos, aplicar el freno de estacionamiento y apagar el motor.
- Mantener las manos, los pies y la ropa alejados de las piezas en movimiento.
- No conducir como pasajero ni llavar pasajeros en máquinas sin asiento para ello.
- Mantener a las demás personas alejadas durante el funcionamiento de la máquina.
- Si no sabe leer ingles, solicitarle a otra persona que le lea y explique el contenido de las etiquetas y del manual de la máquina.

4175842

WARNING

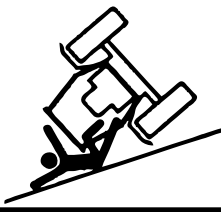

AVOID INJURY OR DEATH FROM ROLL OVER:

Keep roll bar in the raised position and use seat belt.

THERE IS NO ROLL OVER PROTECTION WHEN THE ROLL BAR IS LOWERED.

Lower the roll bar only when necessary and NEVER remove it.

Do NOT use seat belt when the roll bar is down.

Raise the roll bar as soon as clearance permits.

Read and follow all safety instructions and warnings in the operator's manual.

CAUTION

ROLL OVER PROTECTION STRUCTURE

To maintain operator protection and roll bar certification:

Replace a damaged roll bar. DO NOT attempt to repair or modify.

Any alteration of the roll bar must be approved by the manufacturer.

DO NOT exceed the machine weight rating of the roll bar.

WARNING

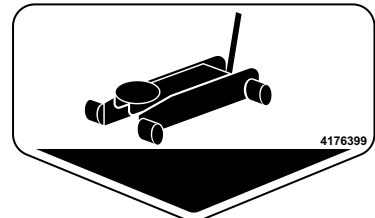
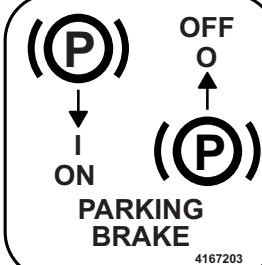

- Rotating parts.
- Do not operate with cover removed.

PARKING BRAKE

4167203

Loosen Bolt to Adjust Handle

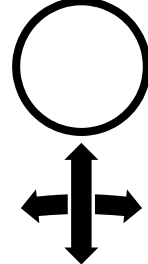

4176717

WARNING



TO CHECK OR ADD FUEL

- Do it outdoors.
- Stop engine. Allow to cool.
- Do not smoke.
- Clean up spilled fuel.
- Do not overfill.
- Fill to one inch below bottom of filler neck.

2000570

LH TANK RH TANK



OFF

4175482



OPERATION & MAINTENANCE MANUAL IS LOCATED UNDERNEATH THE SEAT.

4168517

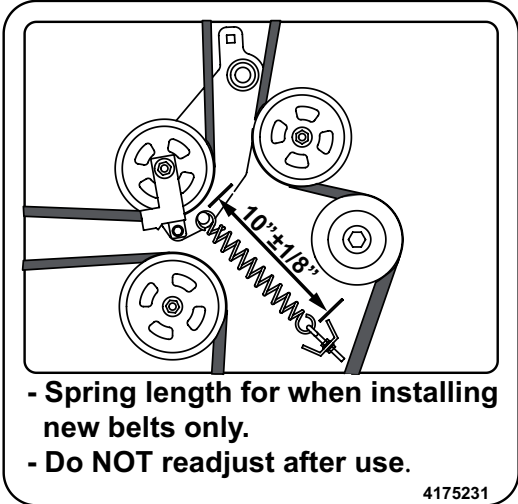
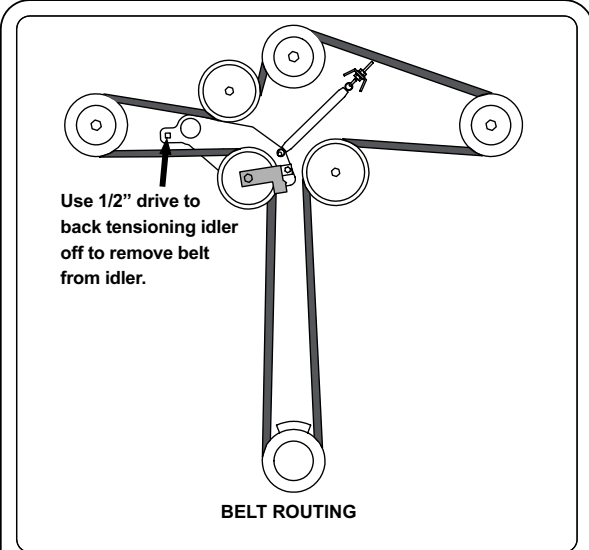

61-in. Deck

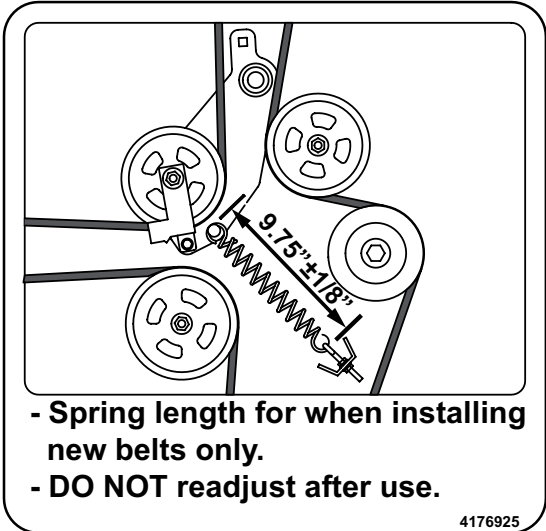
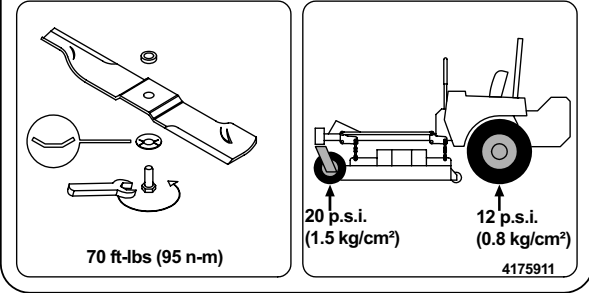

52-in. Deck

WARNING
SPARKS OR FLAME CAN START EXPLOSION.
DISCONNECT (-) NEGATIVE TERMINAL FIRST.
RECONNECT (-) NEGATIVE TERMINAL LAST.

OPERATION & MAINTENANCE MANUAL

- Read and understand
- Replace if lost or damaged

2000735

DANGER
ROTATING BLADES

- Keep hands and feet away.
- Stop engine and let blades stop before removing grass collector or unclogging.

4164269

WARNING
THROWN OBJECTS

- Keep area clear of people and pets.
- Remove objects blade may strike and throw.
- Do NOT operate without chute, mulcher or entire grass collector in place.

4165616

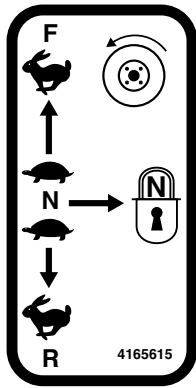
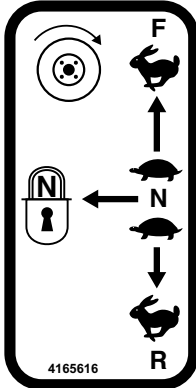

LABELS

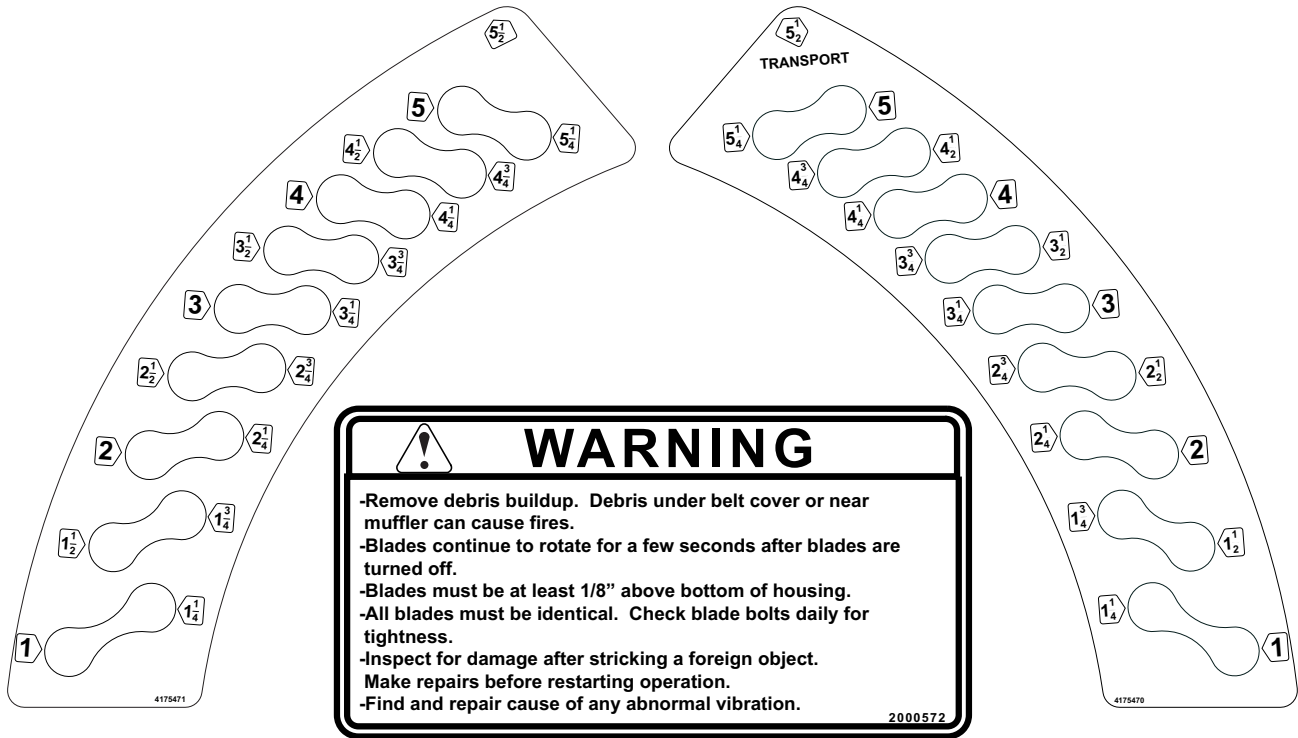

EFI UNITS

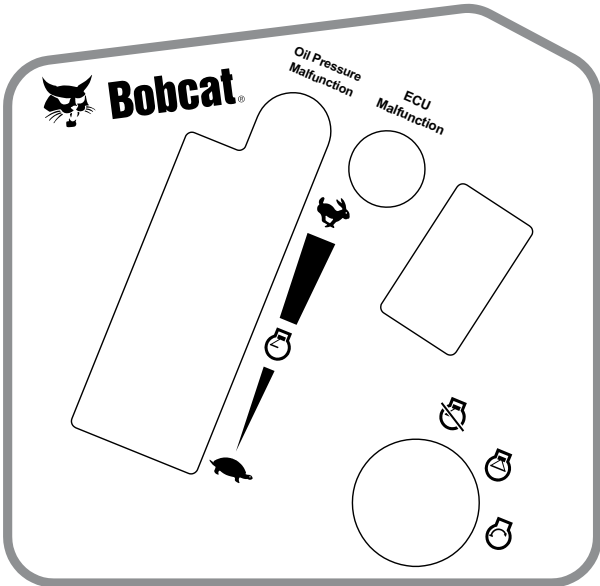

NON-EFI UNITS

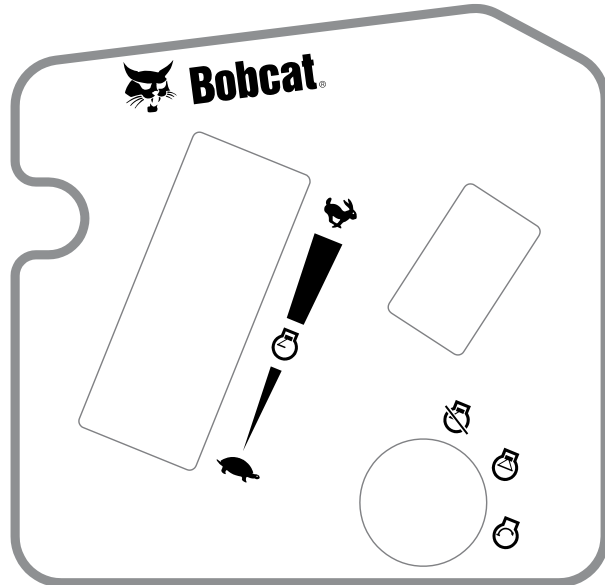

RIGHT SIDE CONTROL PANEL

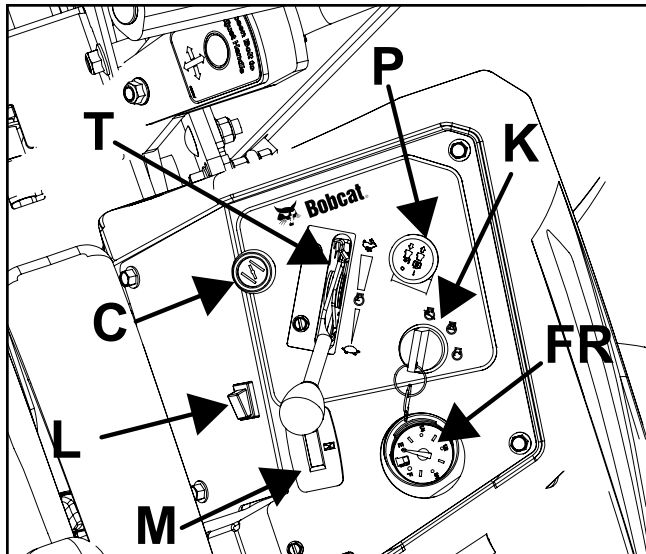

NON-EFI UNITS

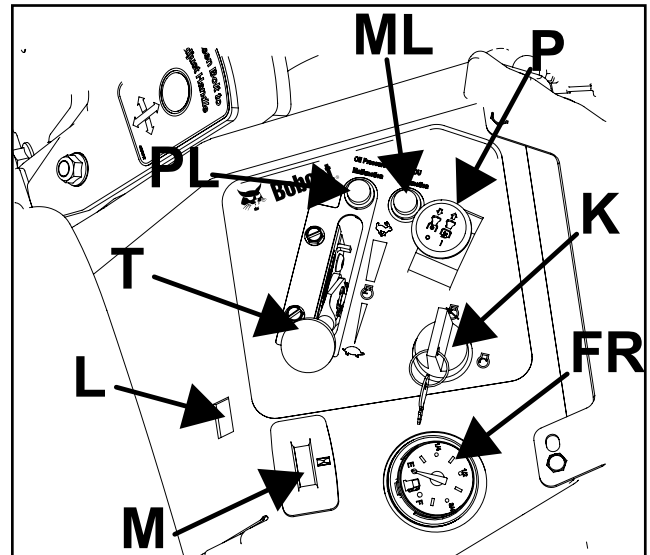

EFI UNITS

THROTTLE (T) - Move the throttle lever forward to increase engine speed until the maximum governed engine RPM is reached. Move the lever rearward to decrease engine speed until the engine reaches its idle speed.

CHOKE (C) - Pull the choke control out to set the choke ON. Push it in to set the choke OFF.

KEYSWITCH (K) - The keyswitch has three positions: OFF, RUN, and START. Insert the key and turn it clockwise to move the switch from OFF to RUN. Turn it further to START and hold to engage the starter. Release the key and the switch will return to RUN from START. Turn the key counterclockwise to OFF to stop the engine.

POWER TAKE OFF (PTO) SWITCH (P) - The operator must be in the seat when engaging the PTO or the engine will kill. Pulling the PTO switch out engages (turns on) the PTO and starts the blades or other attachment. Pushing the PTO switch in disengages (turns off) the PTO and stops the blades or other attachment.

NOTE: The PTO switch does not control attachments powered by a separate engine.

- Disengage the PTO whenever you stop or leave the operator's position.
- Shut off engine with the key and remove the spark plug wires before making adjustments or unplugging a clogged mower.
- Do not engage the PTO until ready to start mowing.

LIGHT SWITCH (L) - Controls headlight on/off (selected models).

FUEL GAUGE RH (FR) - Indicates fuel level in right-side tank.

HOUR METER (M) - Records accumulated time the machine is in operation.

OIL PRESSURE MALFUNCTION LIGHTS

(PL) - Indicates low engine oil pressure when lit.

NOTE: When starting the engine, the indicator light will come on briefly as an engine system check. If the light stays on after initial start-up, shut off engine, and check the oil level. If the indicator light continues to stay on, contact an authorized Bobcat dealer.

ENGINE CONTROL UNIT MALFUNCTION

LIGHT - ECU (ML) - Indicates an issue with the control unit when lit. **NOTE:** When starting the engine, the indicator light will come on briefly as an engine system check. If the light stays on after initial start-up, shut off engine, verify the battery cables are connected properly and the battery is properly charged. If the indicator light continues to stay on, contact an authorized Bobcat dealer.

CONTROLS

FUEL VALVE (U) - A fuel tank selector valve is provided. The fuel tank selector valve has three positions:

Off: The tank selector is off when the lever is centered. The selector should be off whenever the machine is transported or stands unused for any length of time. Shutting off the fuel supply avoids the possibility of flooding should any dirt get under the carburetor float needle. Leaving the tank selector in either tank position can allow severe flooding, which may ruin the engine by diluting the oil.

Right Tank: Fuel flows from the right tank when the selector is turned 1/4 turn toward the right, when facing the valve.

Left Tank: Fuel flows from the left tank when the selector is turned 1/4 turn toward the left, when facing the valve.

FUEL GAUGE LH (FL) - Indicates fuel level in left-side tank.

12V OUTLET (O) - A 12V outlet is provided to accommodate 12V accessories such as cell phone chargers.

SWITCH BLANK (SW) - Shown with the dump switch used with the optional grass collector or towed aerator installed.

Located on left side control panel.

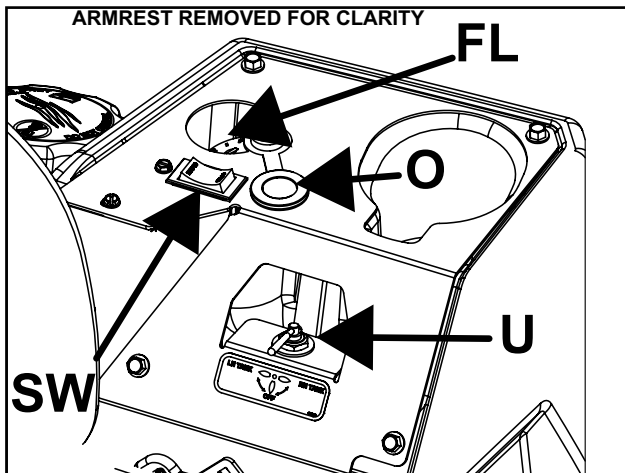

DECK LIFT & TRANSPORT LATCH LEVER (D & T) - Pull back on the deck lift lever **D** to raise the deck. When the deck is completely raised, the transport latch **T** engages to hold the deck in the transport position. To lower the deck, pull back on the lift lever **D**, then raise the latch **T**. Lower the deck lift lever until it contacts height of cut pin **A**.

HEIGHT OF CUT PIN (A) - Sets height of cut and allows easy return from transport to desired height of cut. Raise the deck to transport using the foot pedal and deck lift lever **D**. Position pin **A** in the hole corresponding to the desired height of cut. Lower the latch lever until it rests on pin **A**.

TRACTION LEVERS (L) - Each of the two traction levers controls the drive wheel located on the same side. They control the forward and reverse movement of the machine, provide steering and also provide dynamic braking.

The operator must be in the seat and the parking brake must be OFF or the engine will kill if the traction drive is engaged. To engage traction drive, move the traction levers toward the center of the machine until they are out of neutral lock position.

**Lift and Traction Levers
(operator's right side)**

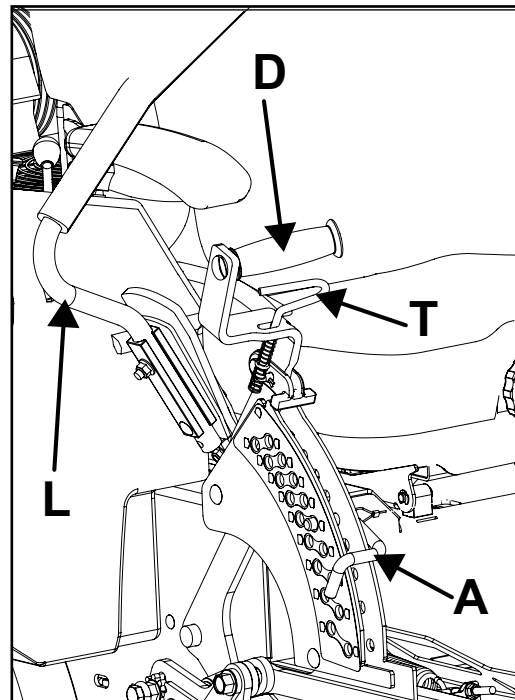

FOOT LIFT PEDAL (F)

The foot lift pedal **F**, allows the operator to raise the mower deck to clear an object without removing his/her hands from the traction controls. The foot pedal may also be used to assist lifting the deck by hand.

Press on foot pedal **F** to raise the deck.

PARKING BRAKE (R) - Pull the parking brake lever up and back to put the parking brake ON. Push it forward and down to put the parking brake OFF.

The parking brake must be ON to start the engine. It must also be ON and the traction levers must be in neutral to keep the engine running if the operator leaves the seat. The parking brake must be OFF to keep the engine running when a traction lever is moved out of neutral lock.

TRACKING ADJUSTORS (W) - Adjusts tracking so machine can drive straight ahead with both traction levers pushed fully forward.

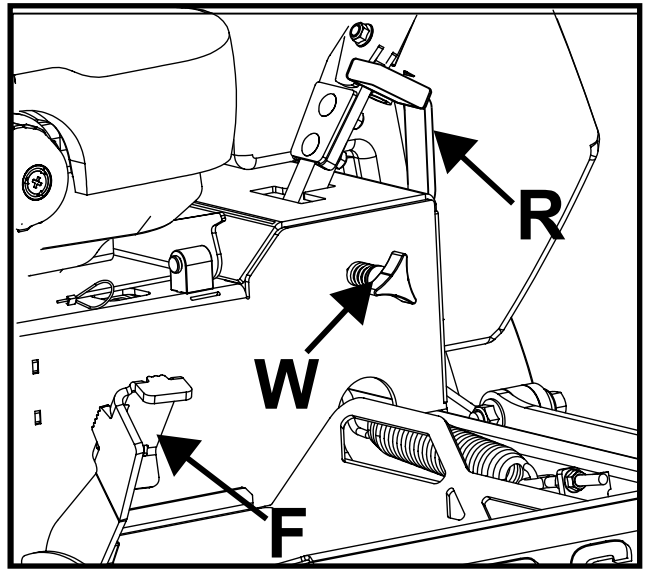

PUSHING THE MACHINE

ZT6000 & ZT6100 SERIES WITH 4400 TRANSAXLES VALVE CONTROL LEVERS

The machine may be pushed with the engine off, parking brake off, and the bypass valves open. Raise the seat to gain access to the two valve control levers **V**. Rotate the levers to the rear until the stop hits to open the valve. To close the bypass valves, rotate the levers forward until the stop hits.

CAUTION

Use caution if it is necessary to tow the machine. With the bypass valves open, the dynamic braking and steering provided by the hydrostats is disabled. Towing should be done only if a disabled machine cannot be repaired where it broke down.

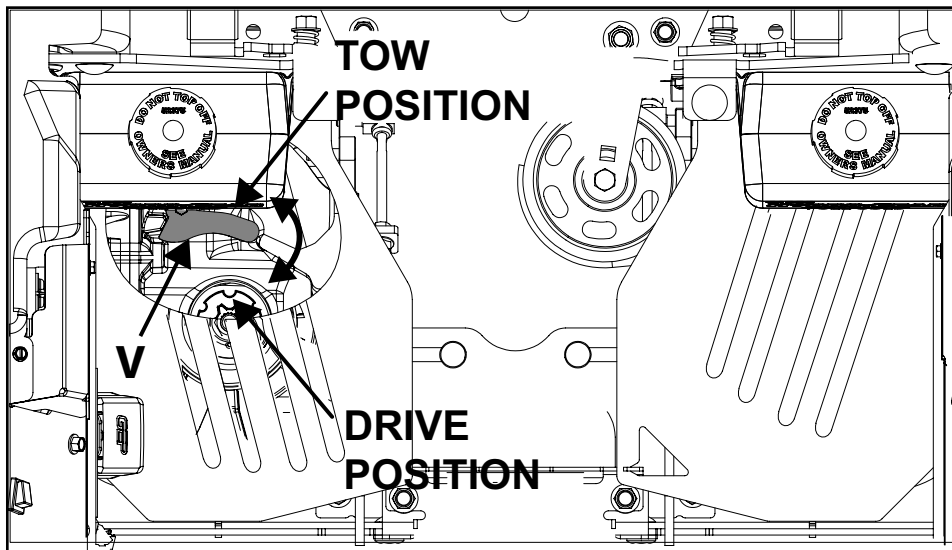

Compartment beneath the seat, viewed from above.
Right side fan guard and fan cut away for clarity.

PRE-OPERATION CHECKLIST

PRE-OPERATION CHECK LIST (OWNER'S RESPONSIBILITY)

- | | |
|---|--|
| <ul style="list-style-type: none">___ Review and follow all safety rules and safety decal instructions.___ Check that all safety decals are installed and in good condition. Replace if damaged.___ Check to make sure all shields and guards are properly installed and in good condition. Be sure that either the discharge shield or complete vacuum attachment is installed.___ Check that all hardware is properly installed and secured.___ Check that equipment is properly and securely attached to power unit.___ Check to be sure engine is free of dirt and debris. Pay particular attention to the cooling fins, governor parts and muffler. Clean air intake screen. Check air cleaner; service if necessary. | <ul style="list-style-type: none">___ Never allow riders.___ Inspect area and remove stones, branches or other hard objects that might be thrown, causing injury or damage.___ Clean area around oil fill dipstick. Remove dipstick and check to be sure oil is in operating range (between marks on dipstick). Add oil if necessary but Do Not Overfill. Install dipstick assembly firmly until cap bottoms out on tube. Dipstick assembly must always be secured into fill tube when engine is running.___ Check all lubrication points and grease as instructed in manual.___ Check hydrostatic fluid level. Check to be sure cooling fins on hydrostat are clean.___ Perform a functional check of the safety interlock system each time you operate the unit. |
|---|--|

OPERATION

FUELING

- Fill fuel tanks with good quality, clean, unleaded gasoline.
- Use a funnel to avoid spillage.

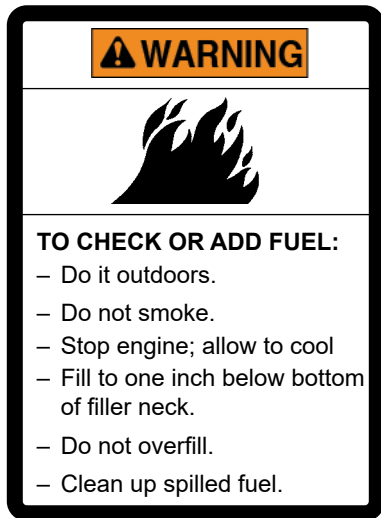

BEFORE STARTING THE ENGINE

- Be familiar with all controls, how each functions and what each operates.
- Check the engine oil level and add if necessary.
- Check the fuel level and add if necessary. Using the fuel selector valve, select which tank will supply fuel.
- **Choke:** For cold starts, set the throttle lever to the half-open position and pull the choke out to the ON position. For warm starts set the throttle to the half-open position and the choke to the OFF position.

OPERATOR PRESENCE INTERLOCK SYSTEM

To start the engine:

- The PTO switch must be **OFF**.
- Both traction levers must be in the neutral lock position.
- The parking brake must be **ON**.

To operate the machine:

1. The operator must be in the seat or engaging the PTO will kill the engine.
2. The parking brake must be **OFF** and the operator must be in the seat, or moving a traction lever from the neutral lock position will kill the engine.

STARTING THE ENGINE

1. Turn the key to operate the electric starter to start the engine. Release the key when the engine starts.
2. If the engine does not start immediately, do not crank for more than 10 seconds at a time. Allow 60 seconds for the starter motor to cool down between starting attempts to prevent the starter motor from burning out.
3. If the choke is ON when the engine starts, gradually back it off until the engine runs with no choke at all.

OPERATING NOTES

- Practice at slow engine and travel speeds with the PTO off until fully familiar with the controls.
- For normal cutting the throttle should be set at the full open position. By using the traction levers to speed up or slow down the machine during use, maximum control and cutting efficiency can be maintained.
- Using the machine at less than full throttle in heavy conditions will cause the engine to labor and result in excessive wear.

DRIVING

1. With the PTO disengaged, move the parking brake to OFF.
2. Move both traction levers out of neutral lock.
3. Push both traction levers forward evenly to drive forward in a straight line. Pull both traction levers back evenly to drive backward in a straight line.
4. **Steering** - Move one lever forward and one back.

Turns during forward movement:

- **Right turn** - move the right traction lever back toward neutral to slow the right drive wheel.
- **Left turn** - move the left traction lever back toward neutral to slow the left drive wheel.

Turns during reverse movement:

- **Reverse right turn** - move the right traction lever forward toward neutral to slow the right drive wheel.
- **Reverse left turn** - move the left traction lever forward toward neutral to slow the left drive wheel.

Slow sweeping turns are made with both traction levers on the same side of neutral and slightly apart. True zero radius turns about the center of the machine are made by having one lever in reverse while the other is in forward. By varying the relative positions of the two levers, the rate of turn is varied to suit the mowing situation.

STOPPING

1. Turn PTO switch to OFF.
2. Release control traction levers or move to neutral.
3. Put machine in PARK.
4. Turn key to OFF (counterclockwise).

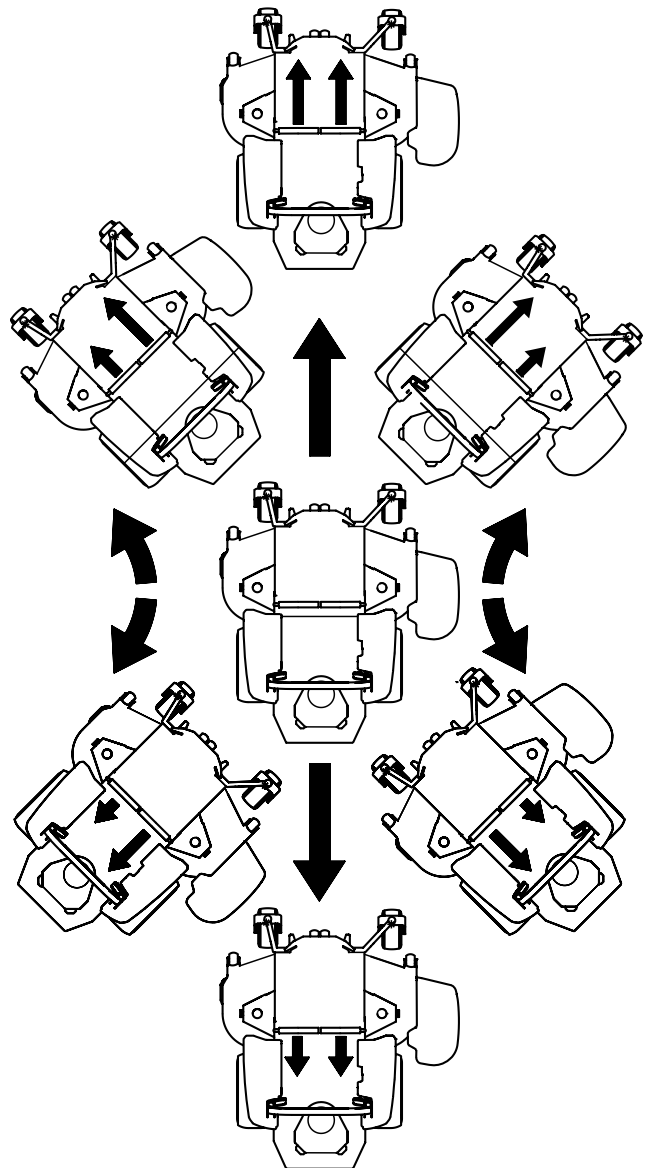

OPERATION

CAUTION

Use caution when making turns. Slow down before making sharp turns to help maintain control and to prevent torn turf from skidding or spinning tires. To help prevent turf damage, keep both drive tires moving whenever a turn is made.

TIP: The best way to make a sharp "zero" turn is to come to a stop, get the machine moving in reverse with both drive wheels and then powering the machine around with the outside wheel. This technique keeps the drive tires turning and results in less turf damage.

	WARNING
	SERIOUS INJURY OR DEATH MAY RESULT FROM MACHINE ROLLOVER <ul style="list-style-type: none">• DO NOT OPERATE MACHINE ON STEEP SLOPES OR NEAR DROP OFFS• ALWAYS USE SEAT BELTS WITH ROPS IN RAISED POSITION• AVOID SHARP AND/OR QUICK TURNS
WARNING	
ROLLOVER MAY CAUSE PERMANENT INJURY OR DEATH. <ul style="list-style-type: none">• ROPS RAISES THE CENTER OF GRAVITY AND REDUCES STABILITY ON SLOPES.• SUDDEN STARTS OR TURNS ON RAMPS OR SLOPES CAN CAUSE OVERTURN.• USE GREATER CARE ON RAMPS AND AS THE SLOPE INCREASES.	

WARNING



- Keep the roll bar in the raised position and wear the seat belt during operation.
- There is no roll-over protection when the roll bar is in the lowered position.
- Lower the roll bar only when necessary.
- Raise the roll bar as soon as clearance permits.
- Check the area before mowing for overhead clearance.
- DO NOT contact overhead objects with the roll bar.

CUTTING

1. Place the discharge chute in the down position or correctly fit a grass collector or mulcher plate.
2. Sit in the seat.
3. Start the engine.
4. Turn the blades on by pulling up on the PTO switch. Do not start the blades at full throttle. Instead, use the slowest throttle setting that will allow the engine to pick up the blade load to reduce the wear on the belts and electric clutch.
5. After the blades are rotating, set the throttle to maximum. Use the traction levers to obtain the required cutting speed, to steer around obstacles and to turn at the end of a cut.

CUTTING TIPS

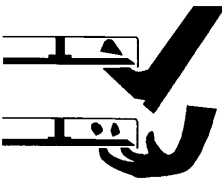
- When mowing large areas, start by turning to the right so that clippings will be discharged away from shrubs, fences, driveways, etc. After two or three rounds, mow in the opposite direction, left hand turns, until finished.
- If grass is extremely tall, it should be mowed twice, the first cut relatively high, the second cut to the desired height.
- Use the left side of the mower for trimming.
- Choose cutting directions so that clippings are thrown onto areas that already have been cut. This method results in the most even distribution of clippings and more uniform, better appearing cuts.
- Use a different mowing pattern each time a property is cut where possible. This helps prevent rutting and leads to a more uniform cut by keeping the grass from always laying the same way.

	 DANGER
	<p>ROTATING BLADES</p> <ul style="list-style-type: none"> – KEEP HANDS AND FEET AWAY. – STOP ENGINE AND LET BLADES STOP BEFORE REMOVING GRASS COLLECTOR OR UNCLOGGING.

	 WARNING
	<p>THROWN OBJECTS</p> <ul style="list-style-type: none"> – KEEP AREA CLEAR OF PEOPLE AND PETS. – REMOVE OBJECTS BLADE MAY STRIKE AND THROW. – STOP BLADES TO CROSS GRAVEL AREAS – DO NOT OPERATE WITHOUT CHUTE, MULCHER OR ENTIRE GRASS COLLECTOR IN PLACE.

MAINTENANCE CHART

MAINTENANCE OPERATION	Maintenance is an ongoing job. These intervals are maximum times between maintenance operations. Perform more often under severe conditions.						
	FIRST 5 HOURS	DAILY	EVERY 25 HOURS	EVERY 50 HOURS	EVERY 100 HOURS	EVERY 200 HOURS	EVERY 400 HOURS
ENGINE							
Consult the engine manual for additional information and instructions							
Check/Top Off Oil Levels		X					
Check For Leaks		X					
Clean Air Intake Screen		X					
Clean Air Cleaner Element		X				X	
Clean Cooling Fins					X		
Change Oil and Filter	X	See engine manufacturer's Manual					
Check/Replace Spark Plugs						X	
TRANSAXLE							
Check/Top Off Oil Level	X				X		
Change Oil And Filter					X*		X
MACHINE							
Check Interlock Operation		X					
Check Tire Pressure		X					
Lubricate All Points				X			

* First 100 hours then every 400 hours.

SPECIFIC TORQUES

BLADE BOLT TORQUE: 70 ft.-lb. (95 Nm)
 WHEEL HUB NUTS: 150 ft.-lb. (203 Nm)
 ENGINE CRANKSHAFT BOLT: 50 ft.-lb. (68 Nm)
 TRANSAXLE PULLEY NUT: 28.3 - 41.6 ft.-lb. (38 - 56 Nm)
 TRANSAXLE FILTER 17-25 ft.-lb. (55 - 65 Nm)
 LUG NUTS 75-100 ft.-lb. (102 - 136 Nm)

MAINTENANCE RECORD

NOTES

GENERAL	DATE	HRS	DATE	HRS	DATE	HRS	DATE	HRS	DATE	HRS	DATE	HRS
Check Tire Pressures												
Lubricate All Points												
Check Nuts & Bolts												
ENGINE												
Check Engine Coolant Level (Where Applicable)												
Check Oil Level												
Change Oil												
Clean Air Cleaner Element												
Clean Cooling Fins												
Replace Air Cleaner Element												
Clean & Gap Spark Plugs												
NOTE: SEE MAINTENANCE CHART FOR SERVICE SCHEDULE												

MAINTENANCE

CHECK DAILY

Operator Presence Interlock System - Start Operation

For the engine to crank, the parking brake must be on, the PTO (blades) off and traction levers in the neutral lock position. Sit in the seat and check, one by one, if the engine will crank with the parking brake off, the blades on, and either traction lever out of neutral lock.

Operator Presence Interlock System - Run Operation

The operator must be in the seat for the engine to run with the parking brake off, the traction levers moved out of the neutral lock position, or the blades on. To check:

1. Start the engine and run at 1/2 throttle with the operator on the machine but raised off the seat.
2. One by one: move the parking brake to the OFF position, traction levers out of the neutral lock position (check each independently), and turn the blades on. Each check should kill the engine after 1/2 second. (A 1/2 second delay is built into the system to prevent engine cutout when traversing rough terrain.)

Repair machine before using if the Operator Presence Interlock System does not operate correctly in start or run. Contact your authorized Bobcat dealer.

Hardware

Tighten any nuts and bolts found loose. Replace any broken or missing cotter pins. Repair any other problems before operating.

Tire pressure

Rear tires are to be inflated to 12 psi (0.82 Bar). Front tires are to be inflated to 20 psi (1.4 Bar). Improper tire inflation can cause rapid tire wear and poor traction. Uneven inflation can cause uneven cutting.

BATTERY-AGM TYPE BATTERY SUPPLIED



WARNING Battery acid is caustic and fumes are explosive and can cause serious injury or death. Use insulated tools, wear protective glasses or goggles and protective clothing when working with batteries. Read and obey the battery manufacturer's instructions.

Be certain the ignition switch is OFF and the key has been removed before servicing the battery.

1. Verify battery polarity before connecting or disconnecting the battery cables.
2. When installing the battery, always assemble the RED, positive (+) battery cable first and the ground, BLACK, negative (-) cable last.

3. When removing the battery, always remove the ground BLACK, negative (-) cable first and the RED, positive (+) cable last.
4. AGM type battery. **Use AGM charger when charging. P/N 4171973**
5. Clean the cable ends and battery posts with steel wool. Use a solution of baking soda and water to clean the battery. Do not allow the solution to enter into the battery cells.
6. Tighten cables securely to battery terminals and apply a light coat of silicone dielectric grease to terminals and cable ends to prevent corrosion. Keep terminal covers in place.

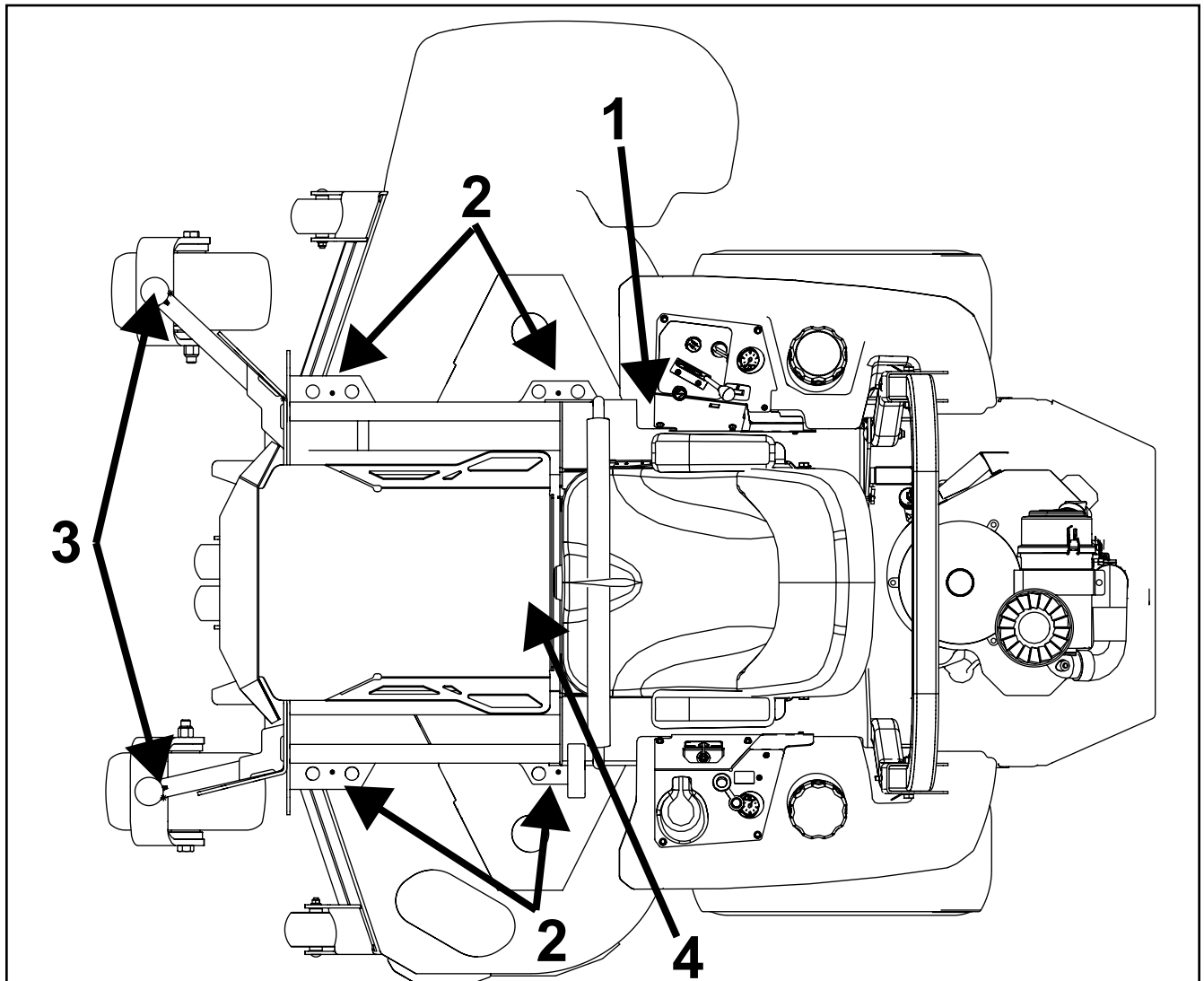

LUBRICATION

Every 50 hours of operation, lubricate the following points (1-4) with grease:

1. Deck lift rockshaft (1 point-lift seat to access)
2. Deck lift pivots (4 points)
3. Caster wheel pivots (2 points)
(Lubricate every 500 hours or once a year)
4. Idler pivot (1 point-lift footplate to access)

NOTE ON BLADE SPINDLES - The blade spindles on these machines use a superior sealed bearing that does not require lubrication.

MAINTENANCE

ENGINE OIL

Do not perform engine maintenance without the engine off, spark plug wires disconnected and PTO disengaged.

AFTER FIRST FIVE (5) HOURS

While the engine is warm:

1. Release the oil drain hose assembly from the engine clip **J**. Route hose assembly through bumper. Hose must be sloped down for oil to drain completely.
2. Remove the rubber cap **D** from the tip of the hose assembly and turn the drain valve to allow oil to drain from the engine. Do not remove the yellow valve completely. Doing so may allow the orange plug to flow out with the oil. Dispose of used oil in accordance with local requirements.
3. Clean drain valve and tighten the plastic portion of the drain valve back into the metal portion of the valve. Replace rubber cap over the tip of the valve. Replace hose assembly back into engine clip **J**.
4. Change oil filter.
5. Fill the crankcase with fresh oil to the full mark. Do not overfill. See engine manual for oil specifications.

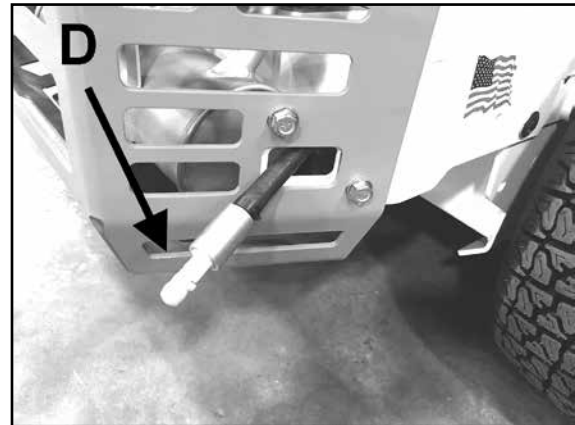
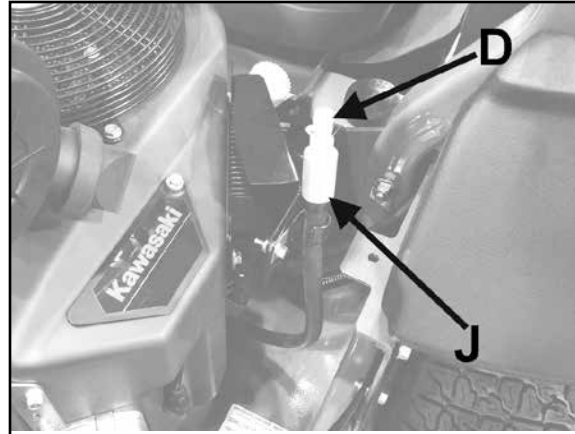

DAILY

1. Check oil level with the dipstick.
2. If oil is needed, add fresh oil of proper viscosity and grade. See engine manual for oil specifications. Do not overfill.
3. Replace dipstick before starting engine.

PERIODIC OIL CHANGES

1. See engine manual for oil and filter change intervals after the break-in period.
2. Follow instructions for first oil change, above.

SPARK PLUGS

Remove each plug and check condition.

- Good operating conditions are indicated if the plug has a light coating of grey or tan deposit.
- A white blistered coating indicates overheating. A black coating indicates an “over rich” fuel mixture. Both may be caused by a clogged air cleaner or improper carburetor adjustment.
- Do not sandblast, wire brush or otherwise attempt to repair a plug in poor condition. Best results are obtained with a new plug.
- Set plug gap as specified in engine manual.

FUEL FILTER

An in-line fuel filter is located in the fuel supply line. Inspect at every oil change to make sure it is clean and unobstructed. Replace if dirty.

ENGINE COOLING

Continued operation with a clogged cooling system will cause severe overheating and can result in engine damage.

- **Daily:** Clean air intake screen **S** on air cooled engines.
- **Every 100 hours:** Clean cooling fins beneath blower housing **H** with reference to information in the engine manufacturer's manual.

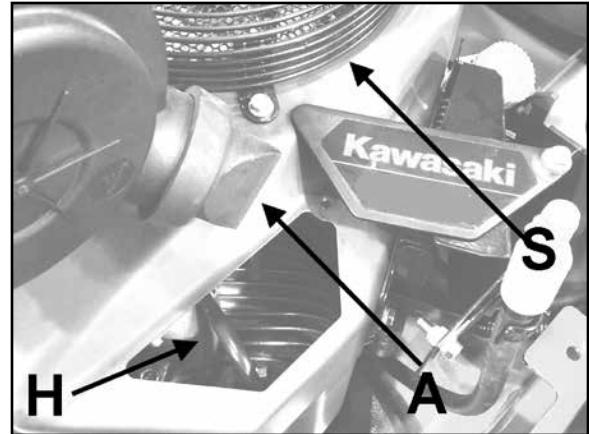

HEAVY DUTY CYCLONIC AIR CLEANER

Clean and replace the air cleaner element as specified in the service chart. Uneven running, lack of power or black exhaust fumes may indicate a dirty air cleaner.

To replace air cleaner elements:

1. Unclamp end cover **X** and remove existing cleaner elements.
2. Insert new elements **Y** and **Z** and replace cover. Ensure the breathing port **A** (previous illustration) is pointing down and towards the front of the machine.

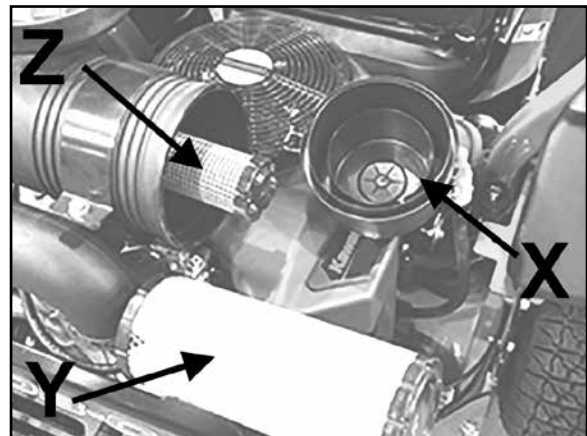

MAINTENANCE

TRANSAXLES

Fluid (oil) level in the transaxle should be checked at every engine oil change or if a leak has occurred. The transaxle does not consume fluid. If fluid level is low check for leaks.

Check the fluid level in the expansion tanks when the machine is cold. If topping off is required, fill only to the "Full Cold" line. DO NOT over fill. The extra space is for expansion as the fluid warms up. If over-filled it is likely that the fluid will overflow when the oil warms up during operation.

Use 15w40 motor oil if topping off is required.

TRANSAXLE OIL CHANGE

Change fluid in the transaxles at the first 100 hour engine oil change and every 400 hours or yearly thereafter.

Approximately 3.5 qts (3.3L) per each transaxle oil capacity.

WARNING

Inattention to proper safety, operation, or maintenance procedures could result in personal injury, or damage to the equipment. Park the machine on a level area, stop the engine, and remove the key. Open the bypass valves (See Page 16). If the machine is raised, support it with jack stands or other suitable means. DO NOT rely solely on a jack.

1. Release the parking brake. Pull the hairpin cotter **HT** and disconnect the brake linkage on each side. Place an oil drain pan (12" or more in diameter and 8 qt. capacity is optimal) beneath the oil filter. Remove the oil filter cover **FC** from the transaxle to drain the oil. Remove the O-ring from the cover and discard the O-ring.
2. After oil has drained from the transaxle, remove the oil filter from the transaxle housing.
3. Install a new filter and a new O-ring onto the filter cover and install the filter cover on machine. Torque the cover to 17-25 ft.-lb. (55 - 65 Nm).

4. Reconnect the parking brake linkage. Fill the transaxle with new 15w40 motor oil through the expansion tank port/ fill port. Filling will be easier if the vent plug **V** next to the expansion tank port is removed. To access the vent plug, remove the nut securing the fan cover on each side. Remove the fan cover. Fill until oil reaches the vent plug. Reinstall the vent plug and continue filling to the "FULL COLD" mark on the expansion tank. Reinstall the fan covers.
5. Drain old oil filter of all free flowing oil prior to disposal. Place used oil in appropriate containers and deliver to an approved recycling collection facility.
6. Purge the transaxles, following the purging procedures.

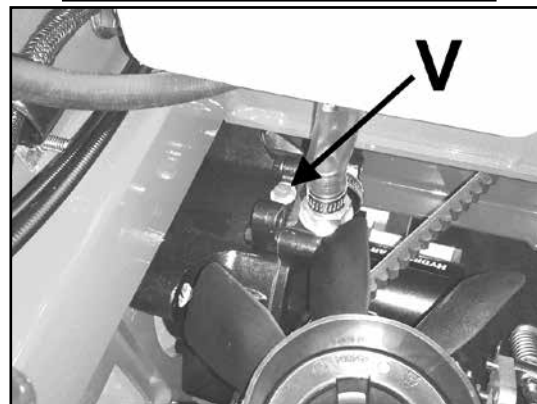
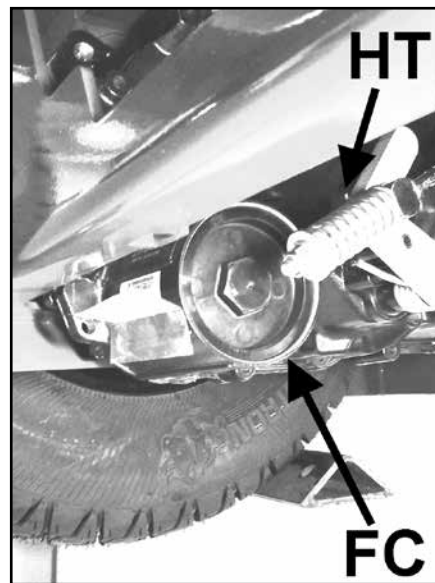

PURGING TRANSAXLES

Any time one of the transaxles has been opened it should be purged to remove air.

Air in the system could result in:

- Noisy operation.
- Lack of power or drive after short term operation.
- High operation temperature, excessive expansion of oil

Before starting, make sure the oil is at the "FULL COLD" level in the expansions tank. If it is not, add 15w40 motor oil to the "FULL COLD" level.

3. Open bypass valves **V**. Raise the drive wheel off the ground.
2. Start the engine and slowly move the traction lever in both forward and reverse 5-6 times. As air is purged, the oil level will drop. Stop the engine.
3. Add 15w40 oil to bring the level back up to "FULL COLD".

4. Close the bypass valve, start the engine and slowly move the traction lever in both forward and reverse 5-6 times. Stop the engine.
5. Check the oil level. Add 15w40 oil to bring the level back up to "FULL COLD".
6. Repeat steps 2 - 5 until the oil level no longer drops. Close the bypass valve once oil level is maintained at "FULL COLD".
7. Lower the machine to the ground. Sit in the seat and operate the machine 5-6 times until the machine responds without lag.
8. Check the oil level and add oil to bring the level back up to "FULL COLD".

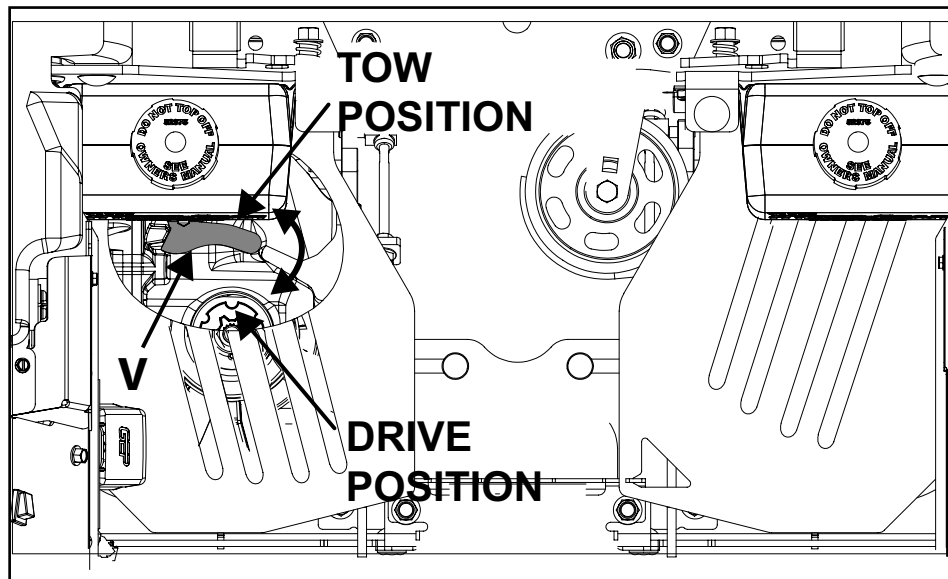

Compartment beneath the seat, viewed from above.
Right side fan guard and fan cut away for clarity.

MAINTENANCE

BLADE REMOVAL

Follow these instructions to prevent injury during blade removal:

1. Loosen with a box wrench or a socket and long breaker bar.
2. Insert wood block **A** as shown, to prevent blade from turning when loosening.
3. Wear thickly padded gloves. Keep hands clear of blade path. Blades may rotate when bolt releases.

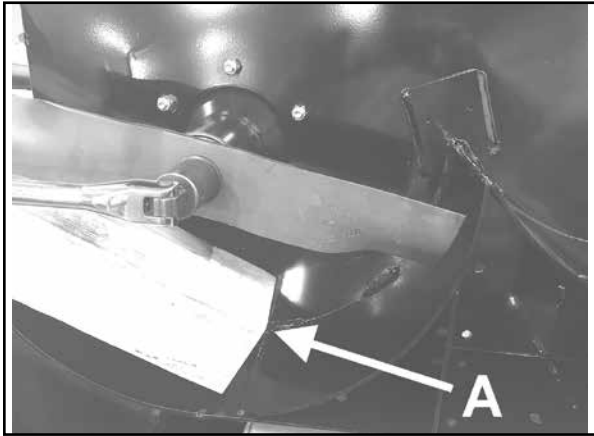

SHARPENING

Blades may be sharpened by filing or grinding.

- Inspect blades before sharpening.
- Replace bent or cracked blades.
- Replace blades when the lift portion has worn thin.
- Maintain cut angle at 30°.
- Do not overheat blades when sharpening.
- Always use Bobcat blades. Use of another manufacturer's blades may be dangerous.

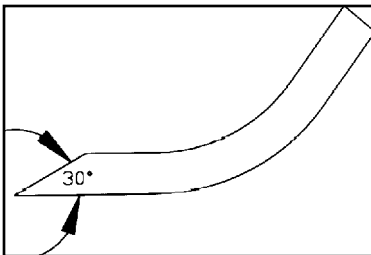

BLADE BALANCE

Blade balance must be maintained at 5/8 oz-in (19.4 g-cm) or less. Failure to keep blades balanced causes excess vibration, wear, and shortened life of most components of the machine.

To balance a blade:

1. Sharpen blade first.
2. Balance the blade at the center.
3. Attach a 1/8 oz (3.9 g) weight at a distance 5-in. (127 mm) from center on the light end. This should make the light end the heavy end:
 - If it does, the blade is balanced.
 - If does not, file or grind the heavy end until the addition of the weight makes the light end the heavy end.

BLADE INSTALLATION

1. Wear thickly padded gloves to prevent cuts from the sharp blade.
2. Insert the blade bolt, in order, through the conical washer (cup side toward the blade, as shown), the blade, and the blade spacer (flat side toward the blade).
3. Install assembly on the blade spindle.
4. Torque the blade bolt to 70 ft.-lb. (95Nm).

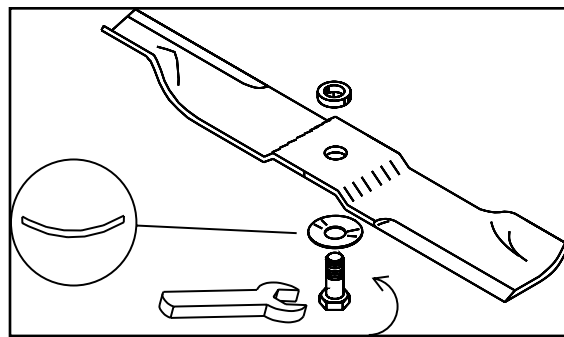

BLADE BOLT TORQUE: 70 ft.-lb. (95 Nm)

BELTS

All belts are tensioned by spring loaded idlers. No adjustment is required.

CLEANING MACHINE

Clean the machine after use. Compressed air is recommended. Do not use a pressure washer. The machine will run cooler and last longer if kept free of clippings and other debris. A clean machine also reduces the risk of fire due to accumulation of combustible debris and chaff.

Brush or blow clippings and debris off the cutterdeck and engine deck. DO NOT use a pressure washer.

WASHING MACHINE

CAUTION: Improperly washing a machine can cause water to enter bearings and other components. This can greatly reduce component life.

- Do not use a pressure washer. Do not direct water at bearings or seals. High pressure water can blow past seals and enter sealed bearings.
- Allow the machine to cool down before washing. Water on a warm machine can be sucked into sealed bearings as they cool.
- Avoid getting electrical connections wet. Water can cause electrical faults and corrosion of electrical components.

STORAGE INSTRUCTIONS

WARNING

To prevent possible explosion or ignition of vaporized fuel, do not store equipment with fuel in tank or carburetor in an enclosure with open flame (for example, a furnace or water heater pilot light).

Daily Storage

1. Check engine oil level and air filter element daily.
2. Check oil level in gear case.
3. Close fuel valve at bottom of fuel tank.
4. Clean cutting blade (grass, dirt, etc.).

EXTENDED STORAGE

Before the equipment is put into storage for any period exceeding 30 days:

1. Drain all fuel from fuel tank and lines (use a hose or fuel line, routed from fuel tank shut-off to proper container).
2. Start engine and run until all fuel is used from the carburetor float bowl.
3. While engine is warm, drain the crankcase oil and refill with the proper weight of oil corresponding to the season when the equipment will next be used.
4. Remove the spark plug and squirt a small quantity of engine oil into the cylinder. Turn the engine over a few times to distribute the oil.
5. Lubricate all lubrication fittings.
6. Clean and oil cutting blade to prevent rust.

To put equipment into operation after an extended storage:

1. Fill fuel tank with clean fresh fuel.
2. Check crankcase oil level, and start engine.
3. Check fuel system for fuel leaks.

ADJUSTMENTS

ROLL-OVER PROTECTIVE STRUCTURE (ROPS)

This machine is equipped with a folding Roll-Over Protective Structure (ROPS).

ROPS in Vertical Position

- Position the ROPS in the vertical position for normal operation. WEAR the seat belt when the ROPS is in the vertical position. In event of a rollover, the seat belt keeps you in the protective envelope of the ROPS.
- If you aren't wearing the seat belt and the machine is overturning, hold onto the steering levers. Do not attempt to jump out or leave the seat. If you leave the seat you may be struck by the machine or the ROPS.

ROPS in Folded Position

- A folding ROPS allows the overall height of the machine to be reduced for increased clearance to get into a low ceiling height trailer or under low hanging branches. DO NOT wear the seat belt when the ROPS is folded. Stop the machine and restore the ROPS to the vertical position as soon as the need for increased clearance is past.

Raising / Lowering ROPS

To Raise ROPS:

On both sides, remove cotter pin **D** from hitch pin **C**. Pull out hitch pin **C** on both sides, rotate upper hoop to the upright position. Reinstall hitch pin **C** and put cotter pin **D** through hitch pin **C** on both sides.

To Lower ROPS:

On both sides, remove cotter pin **D** from hitch pin **C**. Pull out hitch pin **C** on both sides, rotate upper hoop to the lowered position. Reinstall hitch pin **C** and put cotter pin **D** through hitch pin **C** on both sides.

Make sure the hitch pin is through the tube so the ROPS is locked into either the raised or lowered position. If the hitch pin is not through the tube, the ROPS can move and will not provide protection.

Ensure that seat plate is secured using spring-loaded latch. To flip seat forward, push down on handle **X** behind and on either side of the seat, to release latch, then push the seat forward.

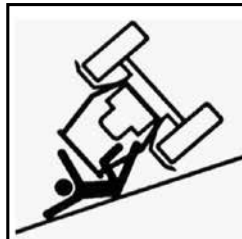

WARNING

SERIOUS INJURY OR DEATH MAY RESULT FROM MACHINE ROLLOVER

- DO NOT OPERATE MACHINE ON STEEP SLOPES OR NEAR DROP OFFS
- ALWAYS USE SEAT BELTS WITH ROPS IN RAISED POSITION
- AVOID SHARP AND/OR QUICK TURNS

ROLLOVER MAY CAUSE PERMANENT INJURY OR DEATH.

- ROPS RAISES THE CENTER OF GRAVITY AND REDUCES STABILITY ON SLOPES.
- SUDDEN STARTS OR TURNS ON RAMPS OR SLOPES CAN CAUSE OVERTURN.
- USE GREATER CARE ON RAMPS AND AS THE SLOPE INCREASES.

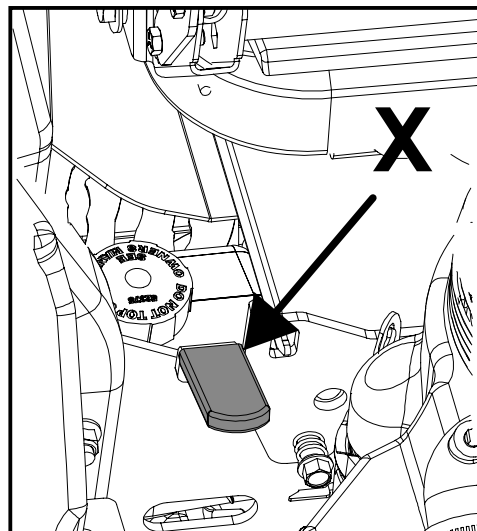
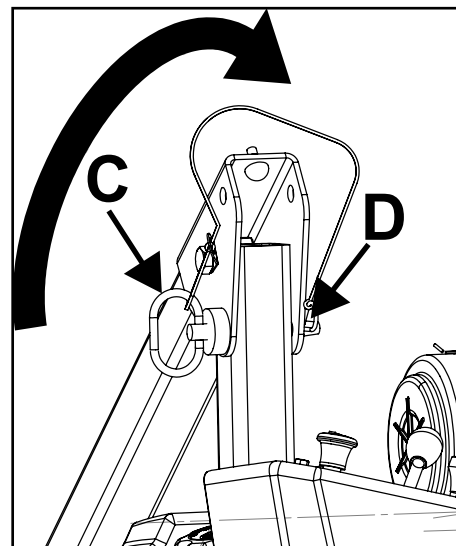

DECK LEVELING

- Park the machine on a smooth, level surface. Raise the deck to the transport position.
- Set tire pressures to 12 psi for the rear tires and 20 psi for the front pneumatic tires. Note: Tire pressure is not applicable to flat-free caster tires.
- Put equal height blocks **A** under the rear corners of the deck and under the front roller brackets. The blocks should be 3-1/2" to 4" high to help minimize effects of the deck counter balance springs.

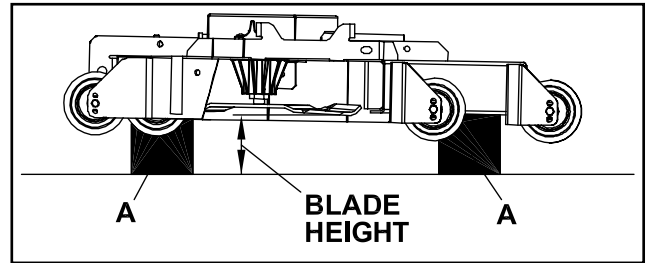

NOTE: The front and rear of the deck are at different heights, but the bottom of the roller brackets matches the bottom of the rear of the deck.

- Lower the deck onto the blocks.
- Loosen nuts **I** at all four corners of the deck to relieve tension on chains **H**.
- Set the height of cut to 1/4" higher than the height of the block being used. Measure the height at a blade cutting edge to confirm the height setting.
- Turn the front adjusting screws **G** to lift the front of the deck off the blocks and snug the front nuts **I** enough to hold the front of the deck in place. This will put enough load on the counter balance springs to keep them from interfering with the rear adjustment. Note: The springs could be disconnected but that is more work.
- Turn the rear adjusting screws **G** to take the slack out of the chains. Stop just as the deck starts to lift off the rear blocks and lock the rear adjustment with nuts **I**. The deck lift lever **J** should be against the height of cut pin **K**.
- Loosen the front nuts **I** and lower the front of the deck to the front blocks with front adjusting screws **G** until the front chains are just taut. Lock the front adjustment with front nuts **I**.

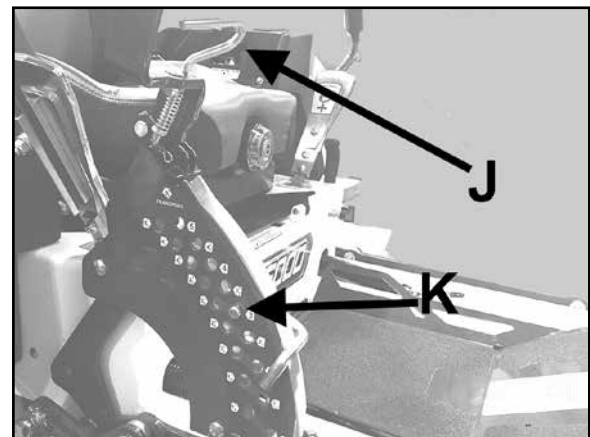
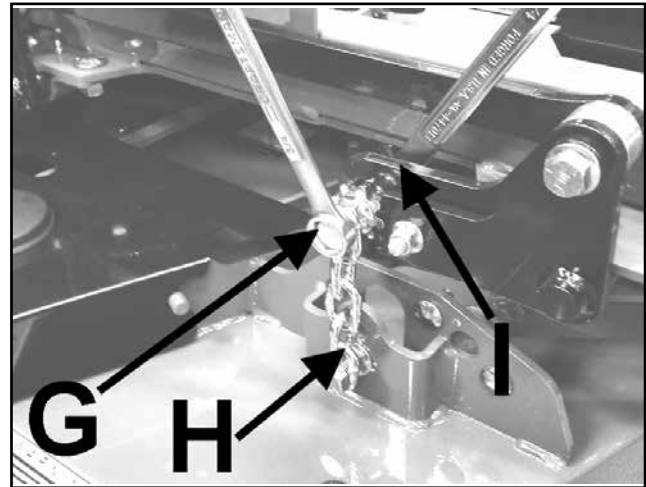

A 1/8" forward pitched deck provides the best horsepower.

A level deck provides the best quality of cut.

A 1/8" rearward pitched deck provides the best striping.

To pitch the deck forward put a 1/8" spacer on top of the rear blocks.

To pitch the deck rearward put a 1/8" spacer on top of the front blocks.

Certain grass types and conditions may vary.

It may not be possible to get everything perfect due to variation in the leveling surface and manufacturing tolerances of the machine. Less than 1/8" variation will not be noticeable under most conditions.

ADJUSTMENTS

HEIGHT OF CUT

- Height of cut may vary due to the amount of tread on the tires, tire diameter or inflation pressure.
- For best results, adjust the deck rollers for the height of cut to be used (see below).

The height of cut is set by moving height of cut pin **K** to the hole designated for the height of cut desired.

To change the height of cut:

1. Using height of cut handle **J** lift the deck to the highest position.
2. Move pin **K** to the selected hole.
3. Lower the deck until the lift lever is stopped by the pin.

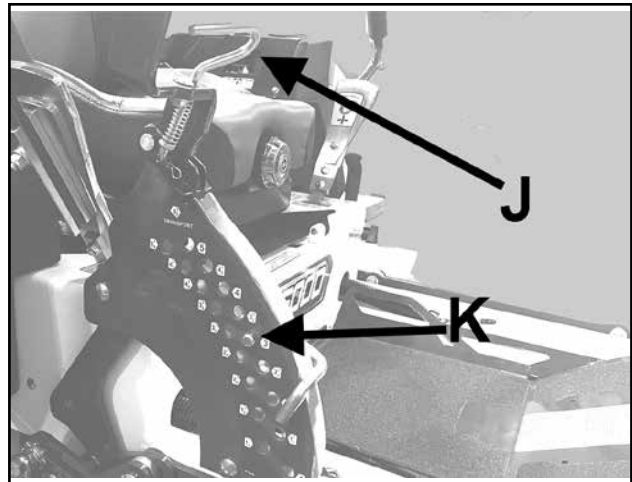

DECK ROLLERS

The deck anti-scalp rollers have three locations to provide improved deck flotation and prevent scalping at various heights of cut. They are not intended to ride continuously on the ground. Adjust no closer than 3/8" (10mm) to the ground.

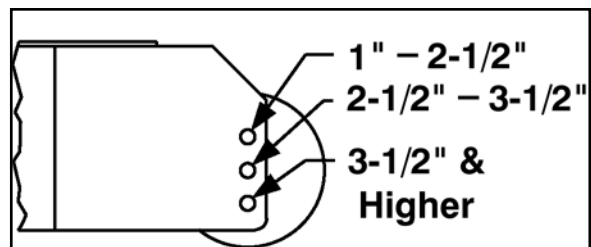

Height of cut ranges for roller adjustment

FOOT LIFT ASSIST

The foot lift may be adjusted to suit the operator. Remove the knob and top bolt. Rotate the pedal to the desired position lining up the hole in the pedal with a square in the arm. Reinstall the bolt and secure with the knob.

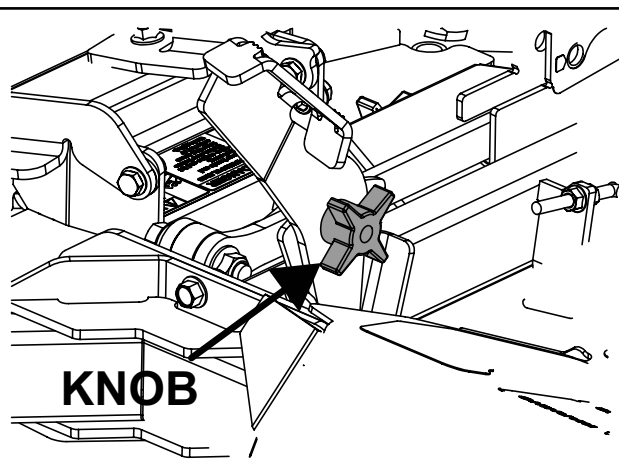
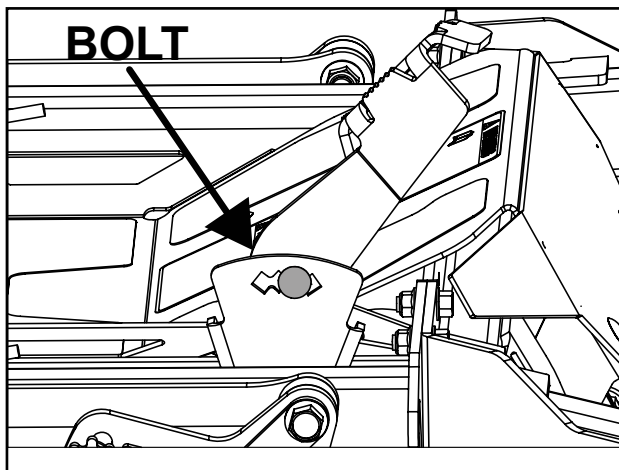

FRONT DECK LIP

Cutterdecks have adjustable front lips to accommodate various conditions.

To adjust per conditions:

1. Loosen the front bolts **S**.
2. Adjust height of **H**.
3. Retighten **S** once you have desired height.

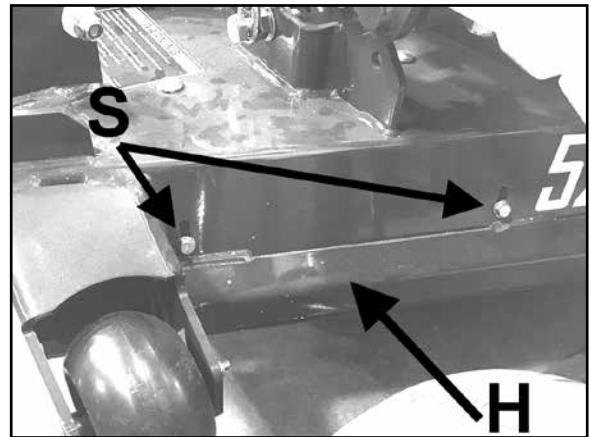

DECK COUNTERBALANCE SPRINGS

The deck counter balance springs make it easier to lift the deck and help it ride up over obstacles. If the springs are over adjusted, the deck may bounce and produce an uneven cut.

To adjust:

1. Raise the cutterdeck all the way and latch it in transport position.
2. Adjust the spring **A** with nut **B**:

The standard adjustment of thread beyond the adjustment nut **B** is 1" for 48" and 52" decks and 1-3/4" for 61" and 72" decks. The nut may be run onto the eyebolt more or less than indicated according to preference.

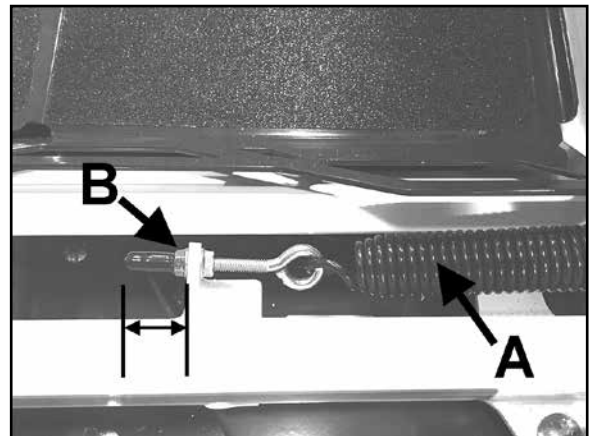

DAMPERS

Dampers are provided on the traction controls; one for each side to make it easier to operate the machine smoothly. There are three mounting positions for each damper.

Center position:

Standard

Outer Position:

Increase the damping and make traction controls stiffer to operate.

Inner Position:

Decrease the damping and make the controls lighter to operate.

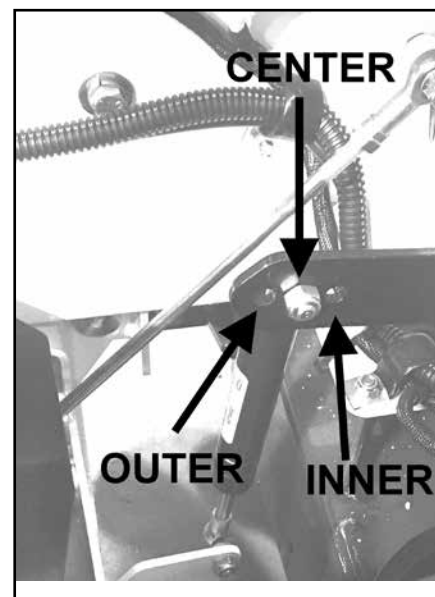

ADJUSTMENTS

TRACTION LEVERS

Lateral Adjustment (LA)

The traction levers are adjustable so they don't rub on the guide slots.

1. Make the traction lever lateral adjustment by putting a 7/16 socket on an extension through the hole in the side of the frame. Turn in the adjusting screw until the traction lever just clears the inside of the guide slot. Repeat for the other side.

Pivot Tension (LA)

The pivot tension is set by a Belleville washer on the pivot bolt.

1. Hand tighten the pivot bolt nut 20 ft.-lb. against the Belleville washer until the nut bottoms on the pivot spacer. Do not over tighten or the spacer may be crushed. If the spacer is crushed, pivoting the lever may be difficult and it will be hard to disassemble the traction control.

Tracking Adjustment (TA)

Tracking adjustment is provided so the machine will go straight when both traction levers are pushed all the way forward.

To adjust:

1. Turn both tracking adjustment knobs all the way in.
2. Gently push the tractor control arm forward. When the traction control stops moving forward (there should be some slot left). Turn the tracking adjuster in until it touches the corresponding control arm so the tracking adjuster limits the stroke of the traction lever rather than the control stops on the hydrostat. Repeat for the other side.
3. Find a suitable level, open area. Get on the machine and start the engine. Run it at half throttle for better control.
4. Point the machine in a safe direction and drive it with both traction levers pushed completely forward. If the machine drives straight you are done. If it drifts off a straight line:
5. Stop the machine, move the traction levers to the neutral position and set the parking brake. Turn in the tracking knob on the outside of the drift 1/6 turn.
6. Drive the machine again and repeat the adjustment until the machine drives straight.

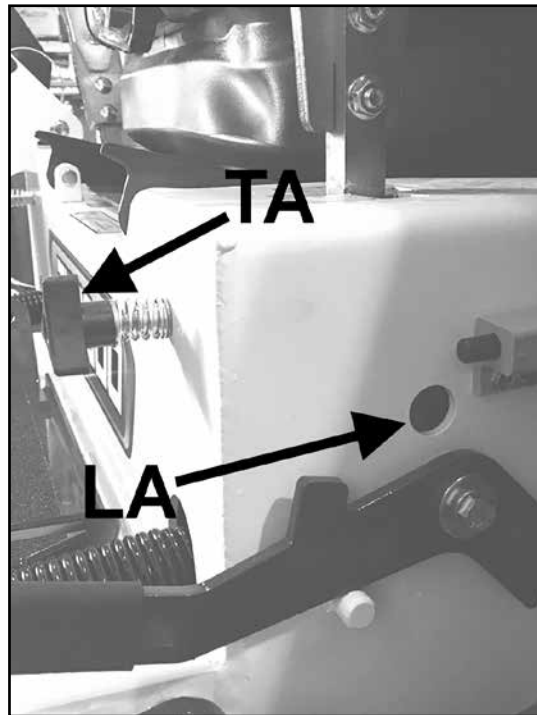

Note: Regardless of tracking adjustment there will be a tendency of the machine to drift to the downhill side of a cross slope.

CONTROL LINKAGE NEUTRAL

To adjust the control linkage to neutral:

1. Move the traction control levers to the neutral lock position.
2. Leave the engine off. Raise the seat for access. Disconnect the cable that limits how far the seat can tilt forward, and tilt the seat forward until it rests on the stops built into the seat.
3. Loosen the jam nut **L** on each end of the control rod. Note the end of the control rod nearest the flats has LH threads. The rod end with an ID groove has matching LH threads.
4. Adjust the rod by turning it so the traction lever moves freely into the neutral lock position. Tighten the jam nut on control rods
5. Move the traction lever out of the neutral lock position and push it to reverse. Let go. The spring return should move the traction lever to where it can tip out centered in the neutral lock slot. If it does not, turn the control rod to lengthen or shorten the assembly until it does line up with the center of the neutral lock slot. Move the traction lever to reverse and let go to check the adjustment. Readjust if necessary.
6. Reconnect the seat cable and lower the seat.

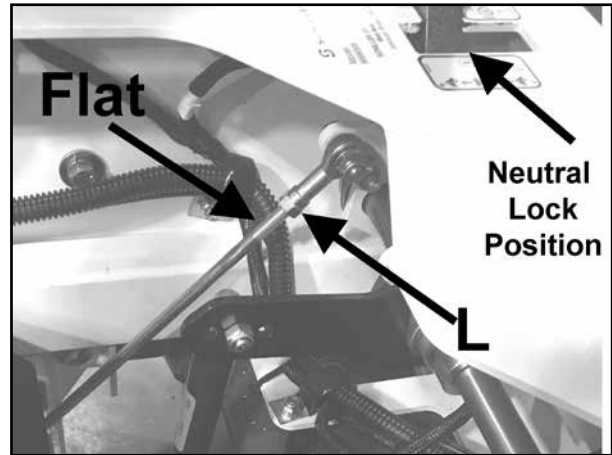

Traction Lever Height and Reach

To adjust the height and reach of the traction levers:

1. Loosen the top traction lever bolt.
2. Adjust the lever up or down and fore or aft to a position that is comfortable for you to operate the machine.



ADJUSTMENTS

HYDROSTAT NEUTRAL ADJUSTMENT

The hydrostats used on this machine are factory set in neutral and should never require adjustment. If for some reason the neutral position on the hydrostat needs to be reset use the following procedure:

1. Raise the machine. Support it on jack stands.
2. Remove the drive wheels to gain access to the control linkage on the hydrostat. Raise the seat to gain access to the control rod assembly. Disconnect the control rod assembly. Make sure the bypass valve is closed. Set the parking brake to the "OFF" position.
3. Note that the control rotates freely in one direction (forward) but is spring load in the opposite direction. This is a unidirectional return-to-neutral (RTN). Loosen the Neutral Lock hex socket head cap screw **A** that locks the neutral arm.
4. Start the engine. Stay clear of any moving parts including the wheel hub.
5. Rotate the entire control assembly, keeping the reverse return side against the neutral arm to the point where the wheel hub stops moving. Tighten the Neutral Lock capscrew, then run the engine up to full speed. Rotate the control lever to forward and back against the reverse stop to check the setting. Readjust if necessary.
6. Stop the engine. Reset the control rod assembly as outlined above under Control Linkage Neutral.
7. Attach the drive wheels and lower the machine to remove the jackstands.

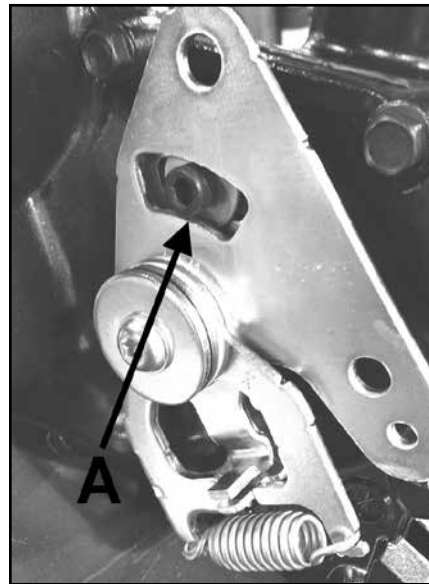

PARKING BRAKE

The parking brake needs to be adjusted so the spring is compressed 1/4" beyond the pre-compression when the brake is applied. Two threads of the brake rod should extend beyond the spring.

1. Loosen the jam **M** nuts locking the brake rod to the brake link.
2. Apply the brake.
3. Adjust the upper nut by tightening or loosening it until the gap between the swage on the rod and the swivel is 5/16". Tighten the other nut on the brake link to lock the adjustment.

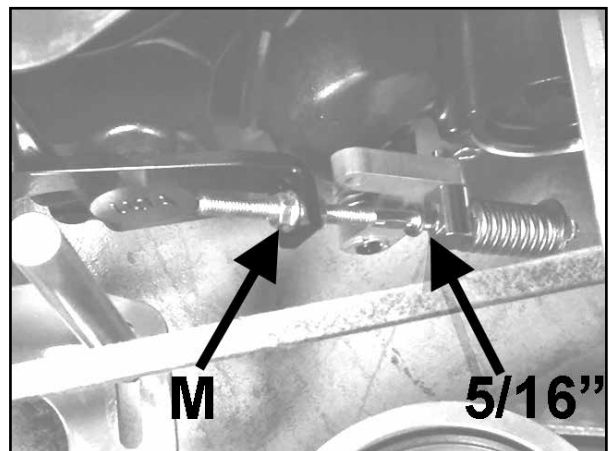

BELT GUIDES

There are two adjustable belt guides for the cutter deck drive belt. The guides should be set 1/8 in.-1/4 in. from the cutter deck drive belt with the height of cut set at 3-1/4 in.

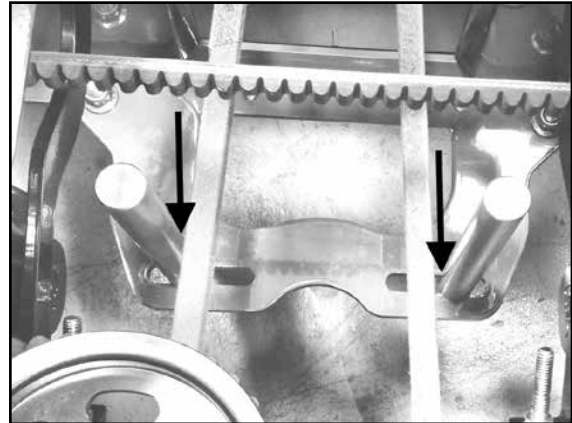

**Adjust distance to
1/8-in. - 1/4-in. between
deck drive belt and guides.**

SPRING TENSIONED IDLERS

There are two spring tensioned idlers. The spring on the transmission belt drive (the upper belt) is not adjustable. The spring on the deck drive belt is adjusted when a new belt is installed. The setting accounts for the seat-in of the belt. The spring should not be readjusted or the belt will be over-tensioned which will lead to premature failure. **See Belt Replacement.**

BELT REPLACEMENT

Note: For best performance use Bobcat replacement belts. Our belts are engineered for the specific drive they are used on and will normally last longer.

CUTTERDECK BELT

1. Set the deck to the middle of the height-of cut range.
2. Tilt the footplate all the way forward. Remove the belt covers on the deck.
3. Loosen the nuts on the tensioning spring eyebolt. Back the tensioning nut off to the end of the eyebolt.
4. Use a 1/2" drive breaker bar and extension to back off the idler to remove the belt from the cutterdeck pulleys.
5. Remove the belt guide from the moveable deck idler.
6. Remove the belt from the clutch pulley on the engine.
7. Install the new belt in reverse order of removal.
5. Adjust the tensioning nut on the eyebolt so the spring is stretched to 9-3/4 in. for 52 in. and 10 in. for 61 in. Tighten the lock nut on the eyebolt to secure the setting.
6. Check the belt guide spacing. Set deck height to 3-1/4 in. Readjust for 1/8 in. - 1/4 in. gap between the guides and the belt if necessary.

NOTE: The cutterdeck belt tension is for a new belt. As the belt runs, the tension will relax. This is accounted for in the initial tension. **DO NOT** re-tension, the belt will be over tensioned and fail prematurely.

NOTE: Spring tension changes as height of cut changes. Set the spring tension at a 3-1/4 in. height of cut.

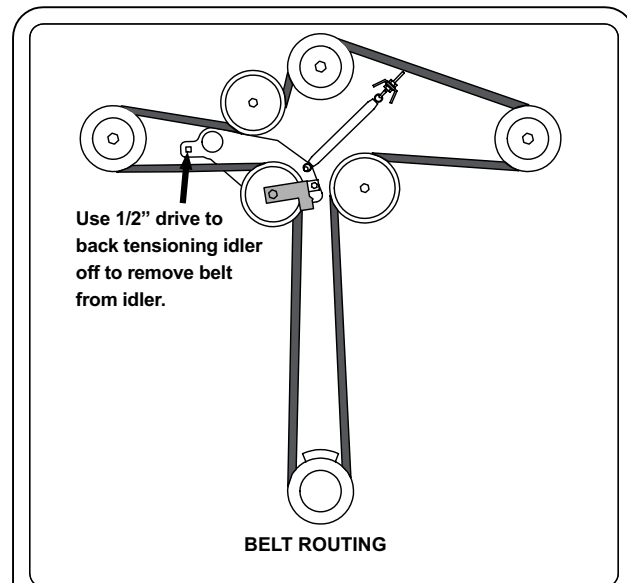

BELT REPLACEMENT

TRACTION DRIVE BELT

1. Set the height of cut to 3".
2. Remove the LH belt cover. Use a 1/2" breaker bar and extension **Figure 1** to back off the deck tensioning idler and remove the cutter deck belt from the LH spindle pulley. Leave the cutter deck belt on the remaining cutter deck pulleys.
3. Raise the rear of the machine on a lift or support it with jack stands.
4. Remove the cutterdeck drive belt from the clutch pulley.
5. Use a 3/8" ratchet handle and long extension **Figure 2** to back off the traction drive tensioning idler and remove the belt from the idler pulley.
6. Finish removing the belt.
7. Install the belt in reverse order of removal.
8. DO NOT change the cutterdeck belt tension. See Cutterdeck Belt.

NOTE: The cutterdeck belt tension is for a new belt. As the belt runs, the tension will relax. This is accounted for in the initial tension. DO NOT re-tension, the belt will be over tensioned and fail prematurely.

NOTE: Cutterdeck belt spring tension changes as height of cut changes. Set the spring tension at a 3-1/4" height of cut.



FIGURE 1

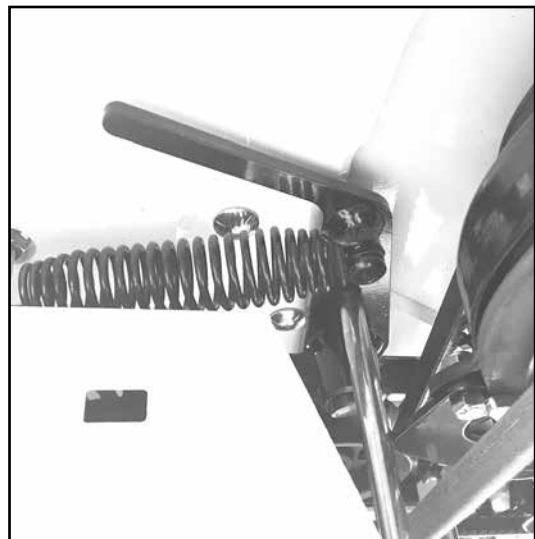

FIGURE 2

SPECIFICATIONS

POWER UNITS

DRIVE SYSTEM:

HydroGear ZT-4400 Hydrostatic Transaxle
Pump: 12 cc/rev (0.73 in³/rev)
Motor: 16 cc/rev (0.97 in³/rev)
Max Torque Output: 780 N•m (575 ft-lb)
Internal wet disc parking brake
Transaxle Oil Capacity 4.5 qts. (4.3L) approx.

MAXIMUM SPEEDS:

Forward: 12 mph (19.3 km/h)
Reverse: 4 mph (6.4 km/h)

OPERATOR PRESENCE

Start Operation

The PTO (blades) must be off, traction levers in neutral lock, and parking brake "ON" for engine to crank.

Run Operation

Operator must be in seat to take parking brake off, to move traction levers out of the neutral lock position, or to turn the PTO (blades) on or the engine will kill. The parking brake must be off for the traction levers to move out of the neutral lock position.

The operator may leave the seat with the engine running if the parking brake is on, the PTO (blades) is off, and traction levers are in neutral lock position. A time delay eliminates nuisance engine cutout from operation over rough terrain.

WEIGHT:

1371 lb. (622kg) w/52" deck and full tanks
1421 lb. (644kg) w/61" deck and full tanks

CONTROLS:

Throttle; choke; power takeoff (PTO) clutch switch; traction levers; parking brake lever; lift lever; foot pedal lift assist.

FUEL SYSTEM:

One tank on each side of operator.
Total capacity: 15 gallons (56.8 liters)
Fuel selector/shutoff valve on left tank panel (1/4 turn).
Replaceable fuel filter

SEAT:

High back, foam padded seat with standard armrests. Fore and aft adjusters, hinged for easy tilt up access to transaxles and battery. Internally mounted seat switch.

WHEELS & TIRES:

Drive wheels:

9996010 & 9996011:
24 X 10.5 -12 4-Ply rated Turf Tread Tires

9996012 & 9996013:

24 X 12.00 -12 4-Ply rated Turf Tread Tires

Casters:

13 X 6.5-6 tires smooth tread pneumatic

Tire Pressure: Rear tires 12 psi (0.82 Bar)
Front tires 20 psi (1.4 Bar)

DECK CONSTRUCTION:

Fabricated and welded 10-gauge, double layered steel top with 7 gauge side skirts. Full floating design.

CUTTERDECK DRIVE SYSTEM:

Electric clutch/brake drives belt directly from engine to cutterdeck. No twists in drive belt.

SPINDLES:

Cast iron, bottom mount. Single row top bearing, double row lower bearing. Pulley easily removed for service.

ANTI-SCALP ROLLERS:

52" & 61"- 6 Rollers

CUTTING HEIGHT:

Height: Spring assisted lift lever allows easy setting of cut heights from 1" to 5 1/2" in 1/4" increments. "Set and forget" feature allows height of cut to be set and returned to without searching from operator position.

SPECIFIC TORQUES

BLADE BOLT TORQUE: 70 ft.-lb. (95 Nm)
WHEEL HUB NUTS: 150 ft.-lb. (203 Nm)
ENGINE CRANKSHAFT BOLT: 50 ft.-lb. (68 Nm)
TRANSAXLE PULLEY NUT:
28.3 - 41.6 ft.-lb. (38 - 56 Nm)
TRANSAXLE FILTER 17-25 ft.-lb. (55 - 65 Nm)
LUG NUTS 75-100 ft.-lb. (102 - 136 Nm)

SPECIFICATIONS

ENGINES				
MODEL NUMBERS	9996010	9996011	9996012	9996013
MANUFACTURER	Kawasaki	Kawasaki	Kawasaki	Kawasaki
MODEL	FX801V	FX801V	FX850V	FX850V-EFI
DISPLACEMENT	852 cc (52.0 in ³)	852 cc (52.0 in ³)	852 cc (52.0 in ³)	852 cc (52.0 in ³)
CYLINDERS	2	2	2	2
BORE / STROKE	84.5 X 76 mm (3.33 X 2.99 in")	84.5 X 76 mm (3.33 X 2.99 in")	84.5 X 76 mm (3.33 X 2.99 in")	84.5 X 76 mm (3.33 X 2.99 in")
COMPRESSION	8.2:1	8.2:1	8.2:1	8.2:1
OIL CAPACITY w/ FILTER	2.4 liters (2.5 US qts)	2.4 liters (2.5 US qts)	2.4 liters (2.5 US qts)	2.4 liters (2.5 US qts)
MAX POWER @ 3600 rpm*	19.0 KW (25.5 HP)	19.0 KW (25.5 HP)	20.1 KW (27.0 HP)	22.01 KW (29.5 HP)
MAX TORQUE @ 2400 rpm*	60.5 N•m (44.4 ft-lb)	60.5 N•m (44.4 ft-lb)	60.5 N•m (44.4 ft-lb)	63.2 N•m (46.6 ft-lb)
DRY WEIGHT	56.4 kg (124 lbs)	56.4 kg (124 lbs)	56.4 kg (124 lbs)	56.6 kg (125 lbs)

* Engines are rated according to SAE J1995 by the engine manufacturer.

CUTTERDECKS		
MODEL NUMBER	9996010	9996011, 9996012, 9996013
TYPE	Side Discharge	Side Discharge
CUTTING WIDTH	52.5" (133cm)	61" (155 cm)
WIDTH (CHUTE UP)	54.3" (138cm)	62.9" (159.7 cm)
WIDTH (CHUTE DOWN)	67.9" (172cm)	76.5" (194.3 cm)
BLADE	high lift (low lift optional)	high lift (low lift optional)
NUMBER OF BLADES	3	3
BLADE LENGTH	18" (46cm)	21" (53 cm)
BLADE THICKNESS	0.205" (5.2mm)	0.25" (6.35 mm)
TIP SPEED	18586 ft/min 5665 m/min @3600 Engine RPM	18850 ft/min 5745 m/min @3600 Engine RPM

